



PARALLEL SHAFT DRIVES

Introductory Information	F-2
Pre-Selection Information	F-3
Quick Selection Tables	F-4
Rating and Dimensions	
Models 251 and 254 - Single Reduction Speed Reducer	F-6, F-7
Model 22 - Single Reduction Speed Reducer	F-8, F-9
Model 230 - Single Reduction Speed Reducer	F-10, F-11
Model 240 - Single Reduction Speed Reducer	F-12, F-13
Model 280 - Single Reduction Speed Reducer	F-14, F-15
Model 85L - Single Reduction Speed Reducer	F-16, F-17
Model 200 - Single Reduction Speed Reducer	F-18, F-19
Model 95L - Single Reduction Speed Reducer	F-20, F-21
Model 95H - Single Reduction Speed Reducer	F-22, F-23
Model 290 - Single Reduction Speed Reducer	F-24, F-25
Model 52 - Double Reduction Speed Reducer	F-26, F-27
Model 83L & 83S - Double Reduction Speed Reducers	F-28, F-29
Model 89 - Double Reduction Speed Reducer	F-30, F-31
Model 1 - Double Reduction Speed Reducer	F-32, F-33
Model 2 - Double Reduction Speed Reducer	F-34, F-35
Model 3 - Double Reduction Speed Reducer	F-36, F-37
Model 4 - Double Reduction Speed Reducer	F-38, F-39
Model 5 - Double Reduction Speed Reducer	F-40, F-41
Model 6 - Double Reduction Speed Reducer	F-42, F-43
Model 75 - Double Reduction Speed Reducer	F-44, F-45
Model 8 - Double Reduction Speed Reducer	F-46, F-47
Model HT100 - Shifting Transmission	F-48, F-49
SAE Standards	F-50 to F-51
Factory Options	F-52



PARALLEL SHAFT DRIVES

Basic Specifications

- Power ratings from 2 to 530 hp
- Output Torque to 120,000 inch/lbs
- Ratios from 1:1 through 70:1
- Output Speeds 24 rpm to 2400 rpm

Standard Features

- Up to three input modes for integrating with hydraulic or electric motors or for externally coupled driving sources.
- Cast iron housing designed for superior thermal conductivity provides rigid gear and bearing support.
- High strength alloy case hardened gears for greater wear life.
- Alloy shafting for greater strength.
- Precision ball bearings or tapered roller bearings for endurance and strength.
- Heavy duty industrial seals to keep contaminants out.

Optional Features

- Modified Standard and Custom Designs
- Optional Output Bore Sizes for Shaft Mount Versions
- CleanLine Washdown and BISSC® Configurations
- Unique or Harsh Environment Adaptations



Motorized Parallel Shaft Drives

- Motors Produced by Marathon Electric for High Efficiency, Reliability and Durability
- General or Definite Purpose Motors
- Brake or Inverter Duty Motors, DC or Washdown Motors
- Motor/Gear Drive Package Incentives Available, Consult Factory

For More Shaft Mounted Reducers See PowerTorque® Shaft Mount Reducers Section G & Poweratio 2000® Compact Helical Parallel Drives Section J

Pre-Selection Information

General Design Features

Hub City parallel shaft speed reducers provide you with a nearly unlimited degree of design flexibility in OEM configurations, or for incorporation in existing systems. Up to three input modes provide for integration with hydraulic motors, electric motors, or for externally coupled driving sources.

Units can be specified for torque to 122,361 lb.-in., horsepower ratings to 530 H.P., and reduction ratios to 70:1, depending on the model and AGMA class of operation required. The wide range of ratios is facilitated by the availability of single and double reduction designs.

Hub City parallel-shaft speed reducers provide the advantages of a sealed, integrated configuration —compact and easily planned into your systems with inherently accurate shaft alignment. A wide range of ratios and ratings offer a selection which can usually be utilized with the driven equipment. These capabilities can also be extended where necessary by use of external V-belts, chains, and other couplings.

All units are designed for long service under heavy-duty conditions, and machined from high alloy grey iron or ductile iron housing castings. The gear drives are equipped with ball, roller or tapered roller bearings, depending on position in the gear train and on operating requirements. Units also include high strength high alloy case hardened gears, double lip seals, and high quality steel shafts and sleeves.

Hub City provides adaptors for most units for both hydraulic and NEMA C Face electric motors, as well as all required bushings, backstops, torque arms, and other accessories that may be required for most applications. Consult each individual reducer dimension page for input styles available.

This catalog includes representative standard Hub City shaft-mounted speed reducers; however, complete engineering capabilities are available to you for development of modified or new designs.

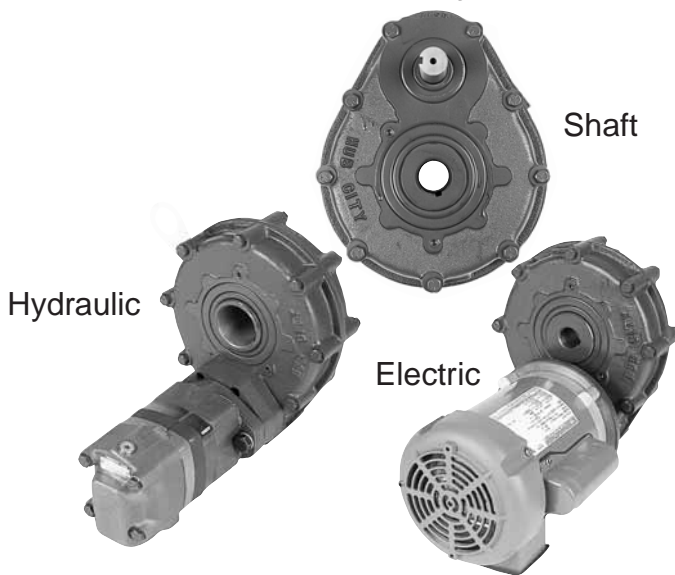

Input Configuration Descriptions

Shaft Input Units – These speed reducers are designed for external coupling through V-belts, chain drives, or other means. Overhung load data can be provided on individual models.

Hydraulic Motor Units – These speed reducers are provided with either a 2-bolt or 4-bolt mounting flange for direct coupling to a hydraulic motor. The hydraulic motor shaft mates directly with the reducer input pinion through a spline or round key adaptor. A “floating” adaptor accommodates any possible concentricity difference.

Electric Motor Units – Hub City speed reducers in this group are equipped with a NEMA “C” flange for direct mounting to a flanged electric motor. The electric motor shaft and reducer input pinion mate coaxially.

Backstops – Optional backstops are offered at extra cost for applications that require the prevention of reverse rotation. Backstops are built-in to the high speed shaft module assembly. Backstops must be factory assembled. When ordering specify desired direction of free rotation of the reducer output shaft – as viewed facing the end of the shaft extension.

Caution: Backstops are not recommended for applications involving energy absorption and shock or torque loads in excess of reducer ratings or on applications such as chair lifts, amusement rides, etc. where the safety of a person or property is dependent on their function. On such applications, other safety devices should be provided.

Backstops

Backstops are designed to prevent rotation not more than five times in an 8 hour period with a minimum of one minute in the over-running direction between each engagement. If reversing operation is more frequent or over-running time is less, the application should be referred to the factory.

NOTE: Lubricants with extreme pressure (EP) additives should not be used in units with built-in backstop.

How To Order

When ordering a Parallel Shaft Drive it is necessary to select a model, gear ratio, input configuration and assembly style where applicable.

For shaft mounted units also specify output bore size.

Input configuration options:

- Shaft
- Hydraulic (specify flange size and input bushing size)
- Electric (specify flange size and input bushing size) (see above for Input Configuration Descriptions)

Not all input configurations are available on all models.

See individual model pages for input configurations available.

HUB CITY PARALLEL SHAFT DRIVES

Quick Model Selection

Hub City Parallel Shaft Speed Reducers can be selected on the basis of speed and torque or horsepower. Quick selection tables on the following pages can be used with 1750 rpm input speed and uniform power source. Table 3 provides reducer selection by H.P. and output speed. It also provides different AGMA load classifications designated for shaft mount reducers. Tables 4 and 5 provide selection by output torque and output speed, for Class I service (1.00 S.F.). Conversion factors for AGMA class II and III are provided below the tables. For other input speeds, and specific rating data, refer to the unit rating tables for each model.

TABLE 1 – SERVICE FACTORS

Prime Mover	Duration of Service Per Day (1)	Driven Machine Load Classification		
		Uniform	Medium Shock	Heavy Shock
Electric Motor	Occasional 1/2 hr.	*	*	1.25
	Intermittent 3 hrs.	*	1.00	1.50
	3 - 10 hours	1.00	1.25	1.75
	Over 10 hours	1.25	1.50	2.00
Electric Motor With Frequent Starts and Stops (2)	Occasional 1/2 hr.	*	1.00	1.50
	Intermittent 3 hrs.	1.00	1.25	1.75
	3 - 10 hours	1.25	1.50	2.00
	Over 10 hours	1.50	1.75	2.25
Multi-Cylinder Internal Combustion Engine	Occasional 1/2 hr.	*	1.00	1.50
	Intermittent 3 hrs.	1.00	1.25	1.75
	3 - 10 hours	1.25	1.50	2.00
	Over 10 hours	1.50	1.75	2.25
Single Cylinder Internal Combustion Engine	Occasional 1/2 hr.	1.00	1.25	1.75
	Intermittent 3 hrs.	1.25	1.50	2.00
	3 - 10 hours	1.50	1.75	2.25
	Over 10 hours	1.75	2.00	2.50
Reversing Service Application		Consult Factory		

* Unspecified service factors should be 1.0 or as agreed upon by user and manufacturer.

Explanatory Notes

1. Time specified for intermittent and occasional service refers to total operating time per day.
2. Term "frequent starts and stops" refers to more than 10 starts per hour.

Table 3 – REDUCER SELECTION: H.P. / OUTPUT SPEED

HP	CLASS I		CLASS II		CLASS III	
	Output RPM	Model	Output RPM	Model	Output RPM	Model
1/4	6-400	52	8-400	52	13-400	52
	10-400	52	13-400	52	20-400	52
1/2	15-400	52	20-400	52	30-400	52
	6-14	1,83,85L	8-19	1,83,85L	10-29	1,83,85L
3/4	23-400	52	33-400	52	48-400	52
	8-22	1,83,85L	12-32	1,83,85L	15-47	1,83,85L
1	31-400	52	43-400	52	64-400	52
	12-30	1,83,85L	16-42	1,83,85L	22-63	1,83,85L
1-1/2	48-400	52	71-400	52	104-400	52
	17-47	1,83,85L	24-70	1,83,85L	32-103	1,83,85L
2	67-400	52	103-400	52	155-400	52
	22-66	1,83,85L	33-102	1,83,85L	44-154	1,83,85L
3	113-400	52	172-400	52	244-400	52
	33-112	1,83,85L	50-171	1,83,85L	72-243	1,83,85L

HP	CLASS I		CLASS II		CLASS III	
	Output RPM	Model	Output RPM	Model	Output RPM	Model
5	208-400	52	320-400	52	139-400	1,83,85L
	61-207	1,83,85L	92-319	1,83,85L	128-138	2
7-1/2	360-400	52	157-400	1,83,85L	223-400	1,83,85L
	102-359	1,83,85L	150-156	2	210-222	2
10	147-400	1,83,85L	217-400	1,83,85L	320-400	1,83,85L
	138-146	2	210-216	2	300-319	2
15	239-400	1,83,85L	362-400	1,83,85L	342-400	1,83,85L
	224-238	2	340-361	2	271-341	3,95L

NOTE: The AGMA Load classes provide for a momentary or starting load of 2.0 times for Class I, 2.8 for class II and 4.0 for Class III

SERVICE FACTORS

The ratings for gear drives in this manual are based on a service factor of 1.00, for uniform load and uniform power source, up to 10 hours of operation per day. For other operating conditions, the application horsepower or torque must be multiplied by the appropriate service factor, to determine the equivalent gear drive power rating. A gear drive should be selected with a rated capacity equal to or greater than the equivalent rating.

AGMA Load Classification Numbers for Gearmotors and Shaft Mount Reducers are listed on pages A-5 and A-6. AGMA Load Classification Numbers for Drives and Reducers are listed on pages A-7 and A-8.

Table 1 designates recommended service factors for various conditions of load, power source, and duration of service.

Table 2 designates load classification numbers for gearmotors and shaft mount reducers with uniform power source, and indicates the relationship between service factors and load classification numbers.

Refer to page A-2 for further information and cautions on the selection of proper service factors.

Table 2 – LOAD CLASSIFICATION NUMBERS

Load class (S.F.)	Up to 3 hrs. Total Operation Per Day	3 to 10 hrs. Total Operation Per Day	Over 10 hrs. Total Operation Per Day
I (1.0)	Moderate Shock Load	Uniform Load	
II (1.4)	Heavy Shock Load	Moderate Shock Load	Uniform Load
III (2.0)		Heavy Shock Load	Moderate Shock Load

HP	CLASS I		CLASS II		CLASS III	
	Output RPM	Model	Output RPM	Model	Output RPM	Model
20	340-400	1,83,85L	331-400	89	380-400	3,95L
	321-339	2	260-330	3,95L	212-379	4
	219-320	89	147-259	4	100-211	5
	174-218	3,95L	66-146	5	70-99	6
	94-173	4	49-65	6	42-69	75
	45-93	5	30-48	75		
	34-44	6				
	22-33	75				
	290-400	89	348-400	3,95L	278-400	4
	236-289	3,95L	192-347	4	127-277	5
25	123-235	4	88-191	5	93-126	6
	58-122	5	64-87	6	52-92	75
	43-57	6	37-63	75		
	26-42	75				
	372-400	89	235-400	4	344-400	4
	284-371	3,95L	111-234	5	164-343	5
	158-283	4	79-110	6	120-163	6
	72-157	5	46-78	75	66-119	75
	53-71	6			59-65	8
	32-52	75				
30	360-400	3,95L	235-400	4	234-400	5
	222-359	4	111-234	5	170-233	6
	106-221	5	79-110	6	97-169	75
	75-105	6	46-78	75	59-96	8
	43-74	75				
	294-400	4	240-300	5	310-400	5
	222-359	4	111-234	5	170-233	6
	100-135	6	86-146	75	130-221	75
	56-99	75	59-85	8	59-129	8
	231-400	5	350-400	5	370-400	6
50	164-230	6	252-349	6	210-369	75
	95-163	75	146-251	75	115-209	8
	306-400	6	270-300	75	339-400	8
	182-305	75	115-269	8		
	382-400	6	343-400	75	339-400	8
	225-381	75				
	200	316-400	75	339-400	8	
	290	339-400	8			



Quick Model Selection

Table 4 – Output Torque Selection

**Single Reduction Speed Reducers
Output Rotation Opposite Input Rotation**

(Selections Based on 1750 Input – For other Input Speeds see Rating Tables)
(Torque Given in Lb.-In. Max., for AGMA Class I Service*)

OUTPUT SPEED (RPM)	MODEL NUMBERS										
	Nominal Ratio	250	22	230	240	280	85L	200	95L	95H	290
1750	1:1	NA	919	NA	NA	3179	NA	5589	NA	NA	14610
1150	1.5:1	NA	1100	NA	NA	NA	NA	6917	NA	NA	17250
875	2:1	738	1237	NA	NA	NA	2800	7336	4962	10750	19590
690	2.53:1	NA	1237	NA	NA	NA	NA	NA	NA	NA	NA
583	3:1	787	NA	713	NA	NA	3290	6602	5657	12100	21535
438	4:1	857	NA	545	1214	NA	3534	6288	6100	12500	24000
350	5:1	913	NA	437	1310	NA	3740	NA	6380	11400	23335
282	6.2:1	NA	NA	NA	1084	NA	3866	NA	6600	NA	NA
240	7.3:1	NA	NA	NA	917	NA	NA	NA	NA	NA	NA
219	8:1	NA	NA	NA	851	NA	NA	NA	NA	NA	NA

* For AGMA Class II Service, divide torque ratings by 1.4; for Class III, by 2.0.

Table 5 – Output Torque Selection

**Double Reduction Speed Reducers
Output Rotation Same As Input Rotation**

(Selections Based on 1750 Input – For other Input Speeds see Rating Tables)
(Torque Given in Lb.-In. Max., for AGMA Class I Service*)

OUTPUT SPEED (RPM)	MODEL NUMBERS											
	Nominal Ratio	52	83L	1	2	89	3	4	5	6	75	8
350	5:1	NA	NA	NA	3871	NA	6452	8536	18968	24935	NA	53002
290	6:1	NA	3833	NA	NA	5475	NA	NA	NA	NA	NA	NA
218	8:1	NA	4025	NA	NA	5829	NA	11314	NA	NA	NA	NA
175	10:1	NA	NA	4241	4395	6013	7336	NA	21649	28297	NA	66871
145	12:1	NA	4318	NA	NA	6196	NA	12136	NA	NA	NA	NA
117	15:1	NA	NA	4485	4651	NA	7813	NA	22969	30000	76851	97235
110	16:1	1667	NA	NA	NA	NA	NA	12714	NA	NA	NA	NA
88	20:1	1765	4790	4873	5093	NA	NA	13395	24957	32597	NA	NA
70	25:1	1882	NA	5161	5076	NA	8460	14265	24873	32487	80624	104607
58	30:1	NA	NA	NA	NA	NA	9191	14644	26800	34909	81506	107060
44	40:1	NA	NA	NA	NA	NA	9532	NA	NA	NA	NA	NA
39	45:1	NA	NA	NA	NA	NA	9624	NA	NA	NA	NA	NA
35	50:1	NA	NA	5559	5803	NA	NA	NA	28406	37101	NA	NA
30	60:1	NA	NA	NA	5824	NA	NA	NA	NA	NA	NA	NA
27	65:1	NA	NA	NA	NA	NA	9737	NA	NA	NA	NA	NA
24	70:1	NA	NA	NA	5859	NA	NA	NA	NA	NA	NA	NA

* For AGMA Class II Service, divide torque ratings by 1.4; for Class III, by 2.0.



HUB CITY PARALLEL SHAFT DRIVES

Models 251 & 254 - Single Reduction

Features

- ◆ Four ratios available from 2:1 to 5:1
- ◆ Can be used as reducer or increaser.
- ◆ Provides additional reduction capability when mounted onto Helical Gear Reducer or Worm Gear Reducer
- ◆ C-flange or solid input shaft.
- ◆ Helical gearing.
- ◆ Double lip seals.
- ◆ Cast aluminum housing.
- ◆ Base mounting available.
- ◆ Permanently lubricated at factory.



SINGLE REDUCTION UNITS PROVIDE OPPOSITE DIRECTION OUTPUT ROTATION

Input RPM*		Ratios			
		2:1	3:1	4:1	5:1
2400	INPUT HORSEPOWER	13.65	9.73	8.16	6.80
	OUTPUT RPM	1200	800	600	480
	OUTPUT TORQUE IN.-LBS.	717	767	857	893
1750	INPUT HORSEPOWER	10.25	7.29	6.09	5.07
	OUTPUT RPM	875	583.3	437.5	350
	OUTPUT TORQUE IN.-LBS.	738	787	878	913
1150	INPUT HORSEPOWER	6.97	4.94	4.12	3.42
	OUTPUT RPM	575	383.3	287.5	230
	OUTPUT TORQUE IN.-LBS.	763	811	903	937
850	INPUT HORSEPOWER	5.26	3.72	3.10	2.57
	OUTPUT RPM	425	283.3	212.5	170
	OUTPUT TORQUE IN.-LBS.	780	827	918	952
690	INPUT HORSEPOWER	4.33	3.05	2.54	2.10
	OUTPUT RPM	345	230	172.5	138
	OUTPUT TORQUE IN.-LBS.	790	837	928	961
300	INPUT HORSEPOWER	1.96	1.38	1.14	0.95
	OUTPUT RPM	150	100	75	60
	OUTPUT TORQUE IN.-LBS.	825	869	961	993
100	INPUT HORSEPOWER	0.68	0.47	0.39	0.32
	OUTPUT RPM	50	33.3	25	20
	OUTPUT TORQUE IN.-LBS.	856	898	990	1020
WR ² (LB.-IN. ²) Referred To High Speed Shaft	Model 251	0.79	0.49	0.37	0.29
	Model 254	0.95	0.65	0.52	0.43
WR ² (LB.-IN. ²) Referred To Low Speed Shaft	Model 251	3.16	4.74	5.91	7.19
	Model 254	3.78	5.87	8.32	10.71

Overhung Load At Center Of Shaft Extension 100-2400 RPM Input	
Input O.H.L.	100 LBS.
Output OHL 7/8" Shaft	500 LBS.

Weight	
Model 251	11 LBS.
Model 254	12.5 LBS.

* FOR HIGHER INPUT SPEEDS, CONSULT FACTORY

Models 251 & 254 - Single Reduction

Model 251

DIMENSIONS SHOWN ARE FOR REFERENCE ONLY. CERTIFIED PRINTS ARE AVAILABLE UPON REQUEST.

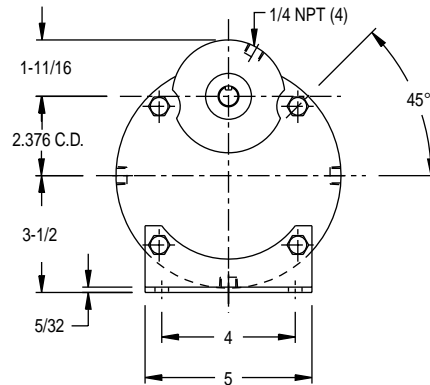
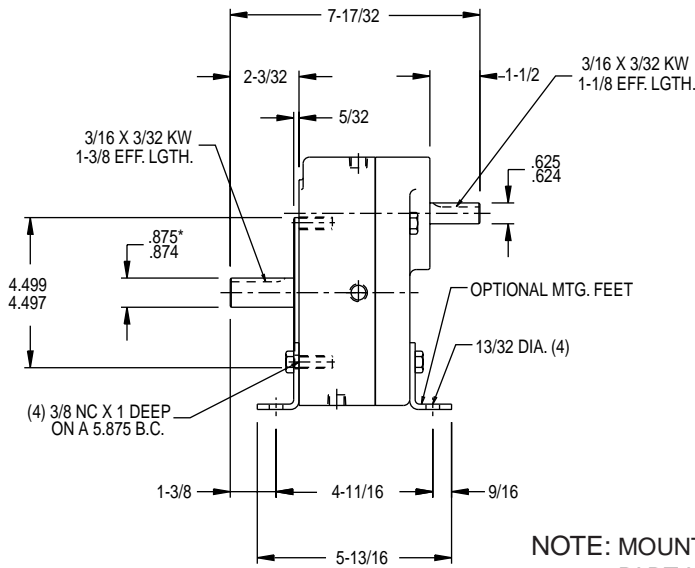

NOTE: MOUNTING FEET AVAILABLE FOR BOTH MODELS AS AN OPTION. PART NUMBER 0229-00099 FOR MODELS 251 AND 254.

Model 254

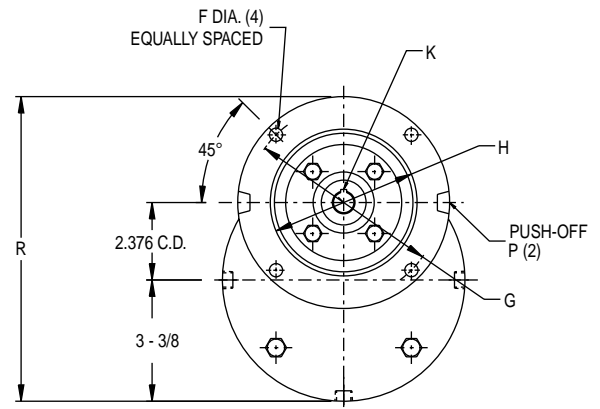
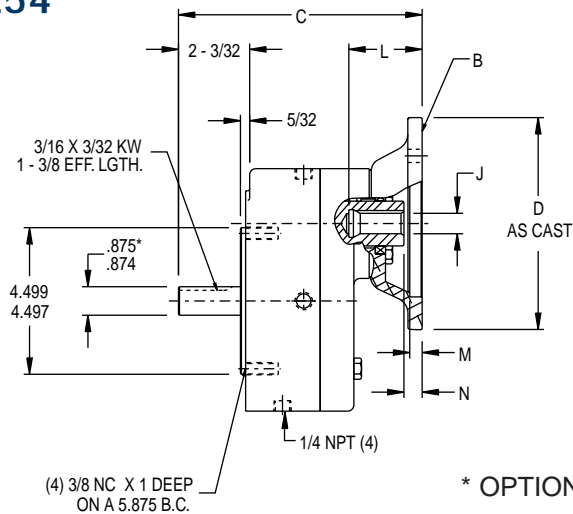

* OPTIONAL $\frac{.625}{.624}$ OUTPUT SHAFT TO BE USED TO CONNECT TO 56C FLANGE ONLY.

NEMA FLANGE	C	D	F	B.C. DIA. G	COUNTER BORE H	MOTOR SHAFT QUILL J	KEYWAY K	L	M	N	P	R
56C	7-17/32	6-17/32	13/32	5-7/8	$\frac{4.501}{4.503}$	$\frac{.6255}{.6270}$	3/16 X 3/32	2-1/4	3/8	9/16	SLOTS	9
143TC, 145TC, 182C, 184C	7-17/32	6-17/32	13/32	5-7/8	$\frac{4.501}{4.503}$	$\frac{.8755}{.8770}$	3/16 x 3/32	2-1/4	3/8	9/16	SLOTS	9
182TC, 184TC, 213C, 215C	8-13/32	9	17/32	7-1/4	$\frac{8.501}{8.504}$	$\frac{1.1255}{1.1270}$	1/4 x 1/8	3-1/8	7/16	13/16	HOLES	10-1/4

NOTE: When 182TC motor flange is used on this unit, additional support should be provided for the motor, or this unit should be supported on a foot mounted motor.

HUB CITY PARALLEL SHAFT DRIVES

Model 22 - Single Reduction

Features

- ◆ Rugged cast iron housing designed for rigid gear and bearing support.
- ◆ Alloy shafting for greater strength.
- ◆ Tapered roller bearings for endurance and strength.
- ◆ Choice of four (4) standard gear ratios.
- ◆ Heat treated alloy steel gearing for strength and long wear life.
- ◆ Heavy-duty industrial seals to keep lubricant in and dirt out.
- ◆ Shaft mount units available. (Style SO.)
- ◆ Foot mount kits available. Part Number 0229-00026.
- ◆ HUB CITY lubricant recommended. (Refer to Section R.)



SINGLE REDUCTION UNITS PROVIDE OPPOSITE DIRECTION OUTPUT ROTATION

Rating Table

INPUT RPM		RATIOS			
		1:1	1.5:1	2:1	2.53:1
1750	INPUT HORSEPOWER	26.3	21.2	17.7	14
	OUTPUT RPM.	1750	1250	875	692
	OUTPUT TORQUE IN. LBS.	919	1111	1237	1237
1150	INPUT HORSEPOWER	18.9	15	12.3	9.9
	OUTPUT RPM	1150	767	575	455
	OUTPUT TORQUE IN. LBS.	1005	1196	1308	1332
850	INPUT HORSEPOWER	15.3	12	10	7.9
	OUTPUT RPM	850	567	425	336
	OUTPUT TORQUE IN. LBS.	1100	1295	1438	1438
690	INPUT HORSEPOWER	12.9	10.2	8.5	6.9
	OUTPUT RPM	690	460	345	273
	OUTPUT TORQUE IN. LBS.	1143	1356	1506	1547
100	INPUT HORSEPOWER	2.3	1.9	1.4	1.1
	OUTPUT RPM	100	67	50	40
	OUTPUT TORQUE IN. LBS.	1406	1742	1712	1701

FOOT MOUNTING KIT

MUST BE ORDERED IN ADDITION TO DRIVE IF REQUIRED.

PART NO. 0229-00026

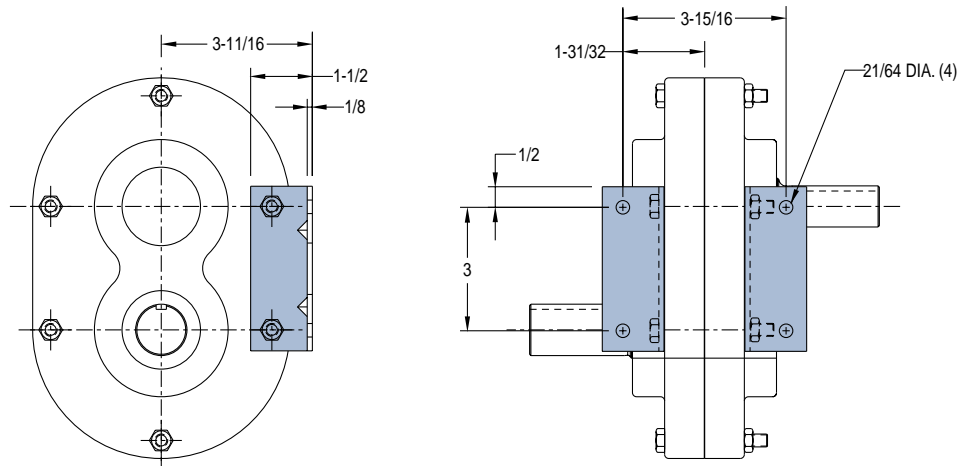

Model 22 - Single Reduction

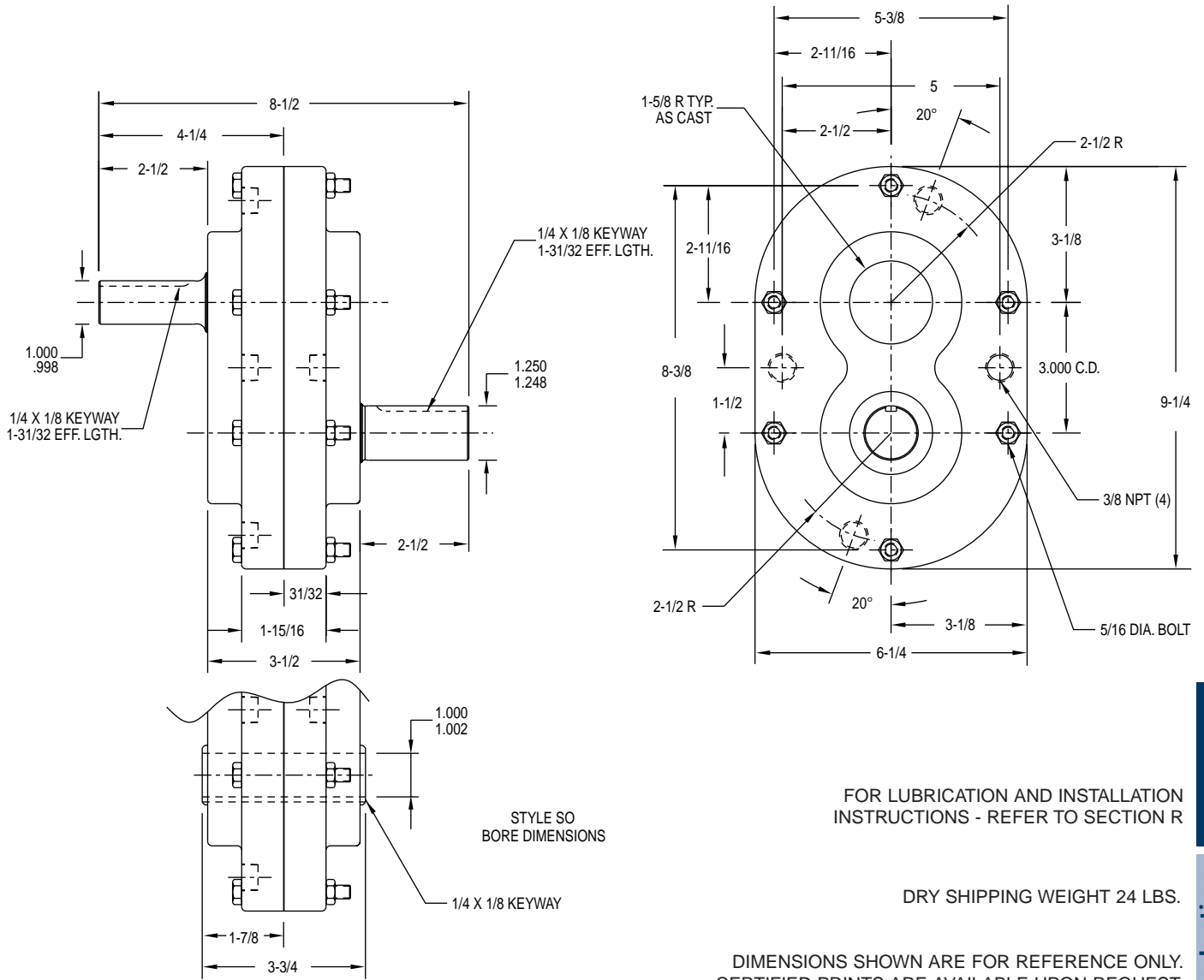

Standard Styles Available

△ INDICATES HIGH SPEED SHAFT.
OTHER STYLES AVAILABLE.

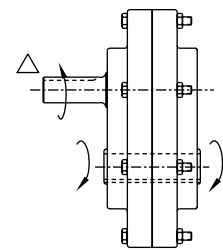
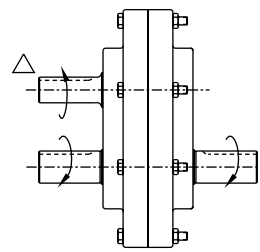
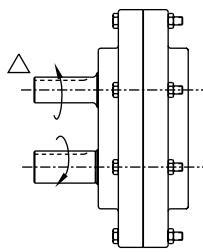
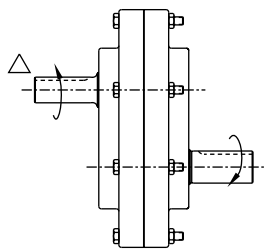

CONSULT FACTORY FOR VERTICAL SHAFT LUBRICATION RECOMMENDATIONS
INPUT SHAFT CAN BE ROTATED IN EITHER DIRECTION

Single Reduction

HUB CITY PARALLEL SHAFT DRIVES

Model 230 - Single Reduction

Features

- ◆ Rugged cast iron housing designed for rigid gear and bearing support.
- ◆ Alloy shafting for greater strength.
- ◆ Heat treated alloy steel pinion and alloy cast iron gear for strength and long life.
- ◆ Needle bearings on high speed shaft. Bronze bushings on low speed shaft.
- ◆ Choice of three (3) gear ratios.
- ◆ Heavy-duty industrial seals to keep lubricant in and dirt out.
- ◆ HUB CITY lubricant recommended. (Refer to Section R)



SINGLE REDUCTION UNITS PROVIDE OPPOSITE DIRECTION OUTPUT ROTATION

Rating Table

INPUT RPM		RATIOS		
		3.11:1*	4.21:1*	5:1
1750	INPUT HORSEPOWER	6.8	3.9	2.5
	OUTPUT RPM	583	438	350
	OUTPUT TORQUE IN. LBS.	713	545	437
1150	INPUT HORSEPOWER	4.5	2.7	1.8
	OUTPUT RPM	383	288	230
	OUTPUT TORQUE IN. LBS.	718	574	478
850	INPUT HORSEPOWER	3.7	2.2	1.4
	OUTPUT RPM	283	213	170
	OUTPUT TORQUE IN. LBS.	798	633	503
690	INPUT HORSEPOWER	3.2	1.9	1.2
	OUTPUT RPM	230	173	138
	OUTPUT TORQUE IN. LBS.	851	673	532
100	INPUT HORSEPOWER	.5	.4	.2
	OUTPUT RPM	33	25	20
	OUTPUT TORQUE IN. LBS.	917	978	611

*MFG. TO ORDER — CONSULT FACTORY FOR PRICE AND DELIVERY.

Model 230 - Single Reduction

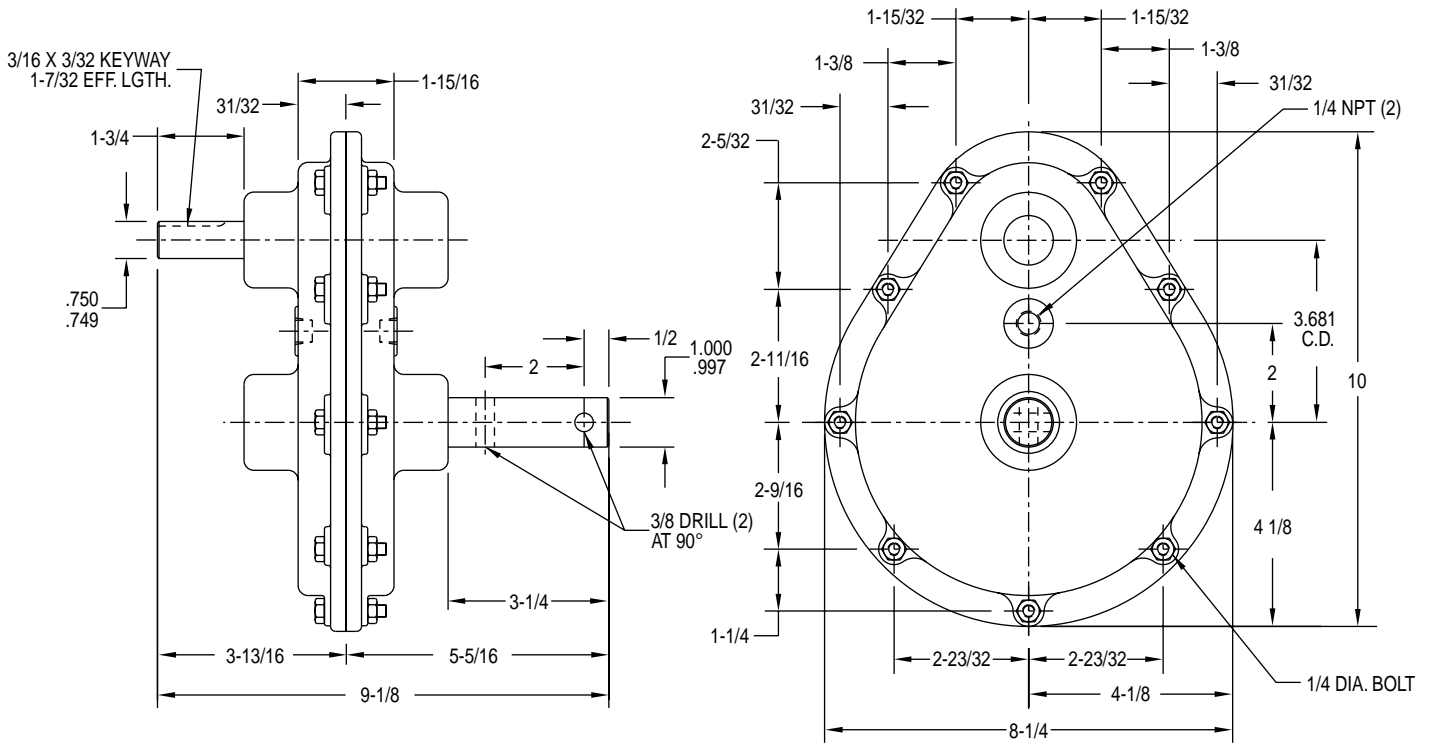

FOR LUBRICATION AND INSTALLATION INSTRUCTIONS - REFER TO SECTION R

DRY SHIPPING WEIGHT 23 LBS.

DIMENSIONS SHOWN ARE FOR REFERENCE ONLY. CERTIFIED PRINTS ARE AVAILABLE UPON REQUEST.

△ INDICATES HIGH SPEED SHAFT. OTHER STYLES AVAILABLE.

Standard Styles Available

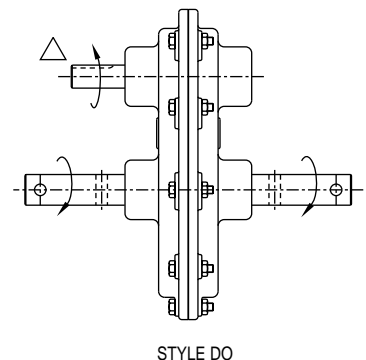
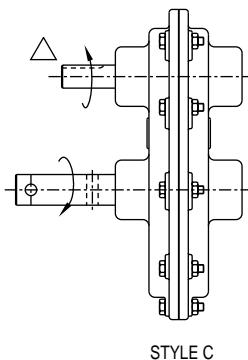
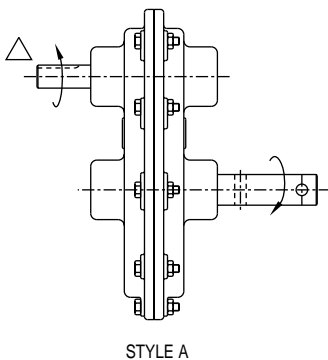

CONSULT FACTORY FOR VERTICAL SHAFT LUBRICATION RECOMMENDATIONS
INPUT SHAFT CAN BE ROTATED IN EITHER DIRECTION

HUB CITY PARALLEL SHAFT DRIVES

Model 240 - Single Reduction

Features

- ◆ Rugged cast iron housing designed for rigid gear and bearing support.
- ◆ Alloy shafting for greater strength.
- ◆ Tapered roller bearings for endurance and strength.
- ◆ Choice of five (5) gear ratios.
- ◆ Heat treated alloy steel pinion and alloy cast iron gear for strength and long wear life.
- ◆ Heavy-duty industrial seals to keep lubricant in and dirt out.
- ◆ HUB CITY lubricant recommended. (Refer Section R)



SINGLE REDUCTION UNITS PROVIDE OPPOSITE DIRECTION OUTPUT ROTATION

Rating Table

INPUT RPM		RATIOS				
		3.95:1*	5:1	6.2:1*	7.3:1*	8:1
1750	INPUT HORSEPOWER	8.8	7.5	5	3.6	3.05
	OUTPUT RPM	443	350	282	240	219
	OUTPUT TORQUE IN. LBS.	1214	1310	1084	917	851
1150	INPUT HORSEPOWER	7	5.5	3.5	2.5	2.1
	OUTPUT RPM	291	230	185	158	144
	OUTPUT TORQUE IN. LBS.	1471	1462	1157	997	892
850	INPUT HORSEPOWER	5.50	4.2	2.7	1.75	1.7
	OUTPUT RPM	215	170	137	116	106
	OUTPUT TORQUE IN. LBS.	1564	1510	1205	922	980
690	INPUT HORSEPOWER	4.5	3.3	2.2	1.7	1.3
	OUTPUT RPM	175	138	111	95	86
	OUTPUT TORQUE IN. LBS.	1572	1462	1249	1093	924
100	INPUT HORSEPOWER	.85	.7	.5	.35	.2
	OUTPUT RPM	25	20	16	14	13
	OUTPUT TORQUE IN. LBS.	2079	2140	1910	1528	941

*MFG. TO ORDER — CONSULT FACTORY FOR PRICE AND DELIVERY.

Model 240 - Single Reduction

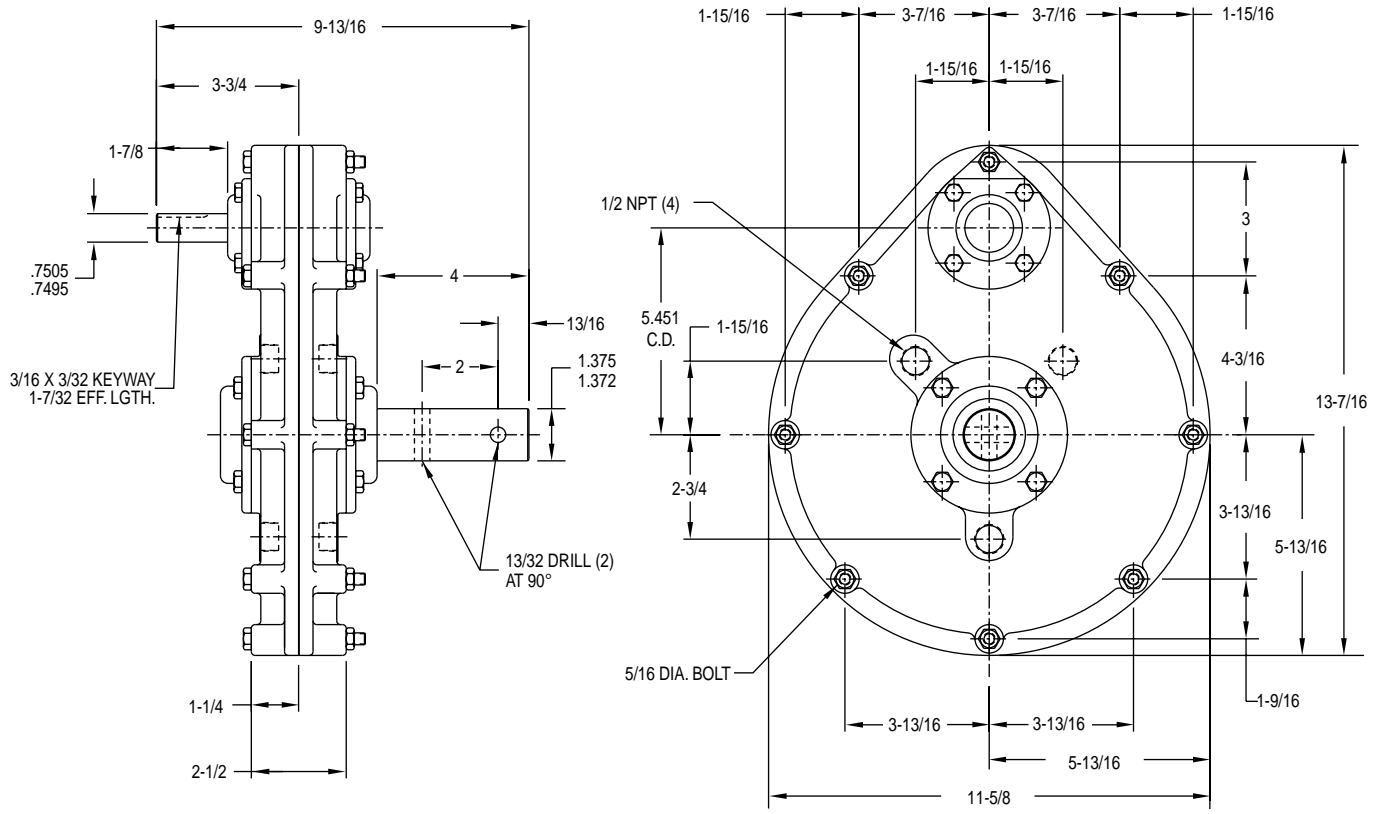

FOR LUBRICATION AND INSTALLATION INSTRUCTIONS - REFER TO SECTION R

DRY SHIPPING WEIGHT 42 LBS.

DIMENSIONS SHOWN ARE FOR REFERENCE ONLY. CERTIFIED PRINTS ARE AVAILABLE UPON REQUEST.

Standard Styles Available

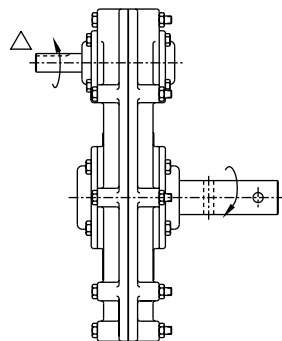

STYLE A

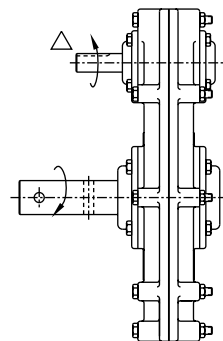

STYLE C

Δ INDICATES HIGH SPEED SHAFT. OTHER STYLES AVAILABLE.

CONSULT FACTORY FOR VERTICAL SHAFT LUBRICATION RECOMMENDATIONS
INPUT SHAFT CAN BE ROTATED IN EITHER DIRECTION

HUB CITY PARALLEL SHAFT DRIVES

Model 280 - Single Reduction

Features

- ◆ Rugged cast iron housing designed for rigid gear and bearing support.
- ◆ Alloy shafting for greater strength.
- ◆ Tapered roller bearings for endurance and strength.
- ◆ Heat treated alloy steel gearing for strength and long wear life.
- ◆ Helical gears for greater strength and lower noise level.
- ◆ Heavy-duty industrial seals to keep lubricant in and dirt out.
- ◆ HUB CITY lubricant recommended. (Refer to Section R)



SINGLE REDUCTION UNITS PROVIDE OPPOSITE DIRECTION OUTPUT ROTATION

Rating Table

INPUT RPM		RATIO
		1:1
1750	INPUT HORSEPOWER	91
	OUTPUT RPM	1750
	OUTPUT TORQUE IN. LBS.	3179
1150	INPUT HORSEPOWER	67
	OUTPUT RPM	1150
	OUTPUT TORQUE IN. LBS.	3562
850	INPUT HORSEPOWER	52
	OUTPUT RPM	850
	OUTPUT TORQUE IN. LBS.	3740
690	INPUT HORSEPOWER	44
	OUTPUT RPM	690
	OUTPUT TORQUE IN. LBS.	3898
100	INPUT HORSEPOWER	8
	OUTPUT RPM	100
	OUTPUT TORQUE IN. LBS.	4891

Model 280 - Single Reduction

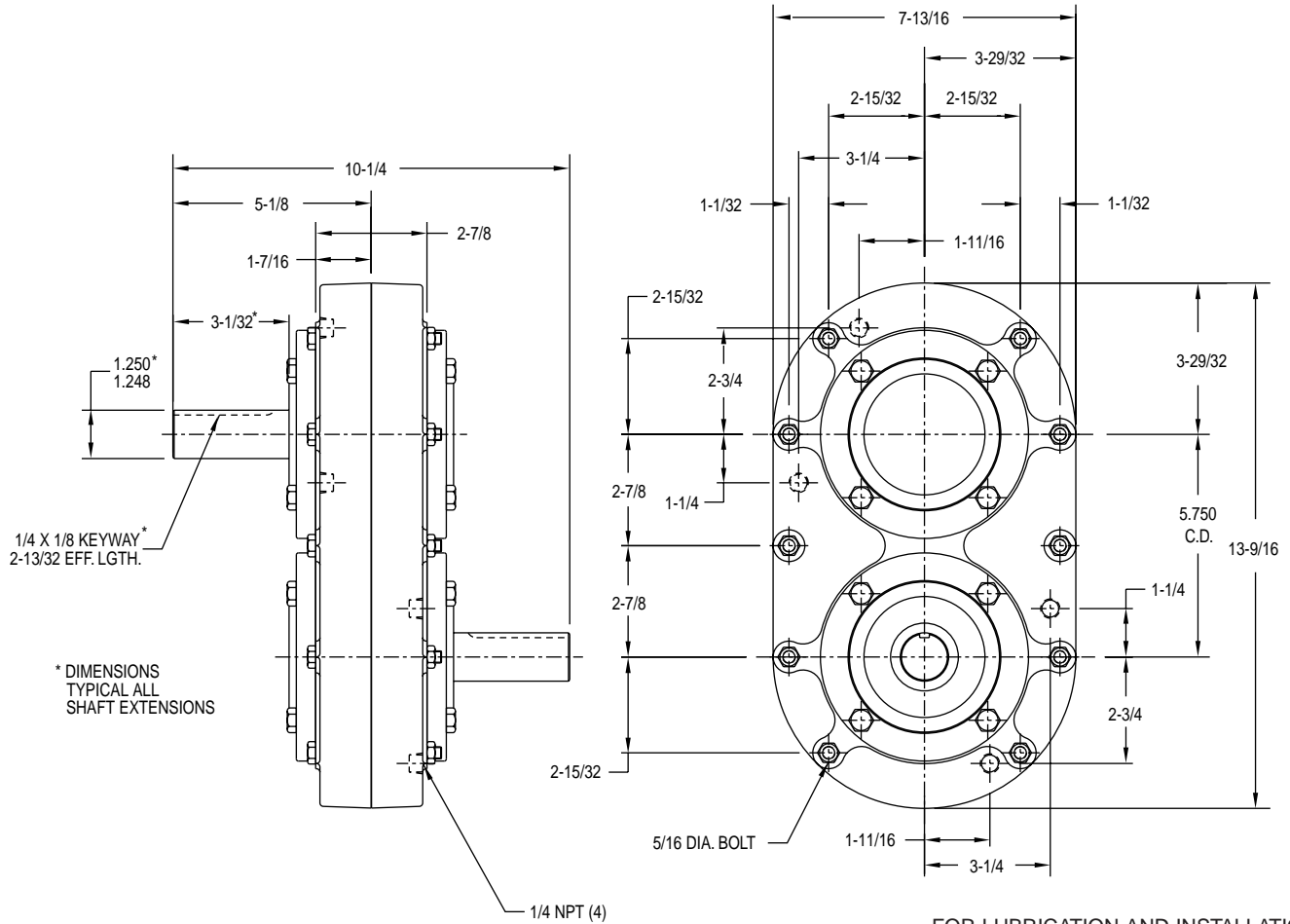

FOR LUBRICATION AND INSTALLATION INSTRUCTIONS - REFER TO SECTION R

DRY SHIPPING WEIGHT 62 LBS.

DIMENSIONS SHOWN ARE FOR REFERENCE ONLY. CERTIFIED PRINTS ARE AVAILABLE UPON REQUEST.

△ INDICATES HIGH SPEED SHAFT. OTHER STYLES AVAILABLE.

Standard Styles Available

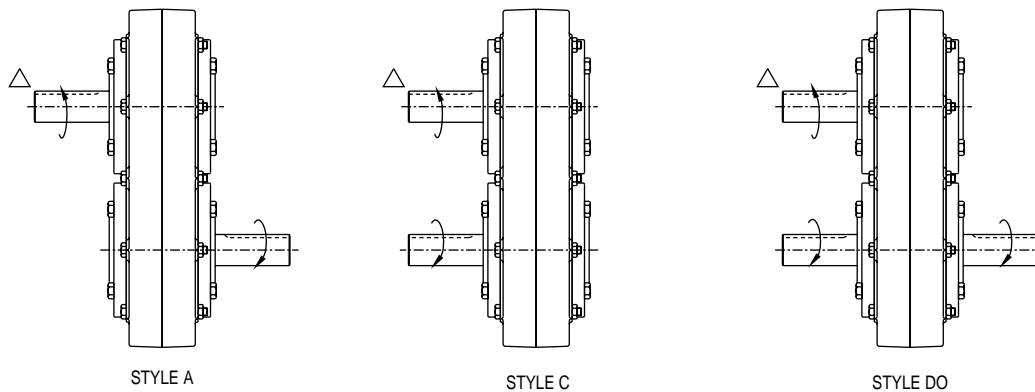

CONSULT FACTORY FOR VERTICAL SHAFT LUBRICATION RECOMMENDATIONS
INPUT SHAFT CAN BE ROTATED IN EITHER DIRECTION

HUB CITY PARALLEL SHAFT DRIVES

Model 85L – Single Reduction

Features

- ◆ Rugged cast iron housing designed for rigid gear and bearing support.
- ◆ Alloy shafting and sleeves for greater strength.
- ◆ Ball bearings on all shafts.
- ◆ Choice of five (5) standard ratios.
- ◆ Heat treated alloy steel gearing for strength and long wear life.
- ◆ Heavy-duty industrial seals to keep lubricant in and dirt out.
- ◆ Shaft mount design for direct mounting on the drive shaft of equipment to be driven.
- ◆ HUB CITY lubricant recommended. (Refer to Section R)
- ◆ Unit may be operated as a speed increaser or speed reducer.



SINGLE REDUCTION UNITS PROVIDE OPPOSITE DIRECTION OUTPUT ROTATION

Rating Tables

INPUT RPM		SPEED REDUCER RATIOS				
		2.04:1	3.12:1	4.00:1	5.00:1	6.09:1
1750	INPUT HORSEPOWER	38.5	29.6	24.8	21.0	17.8
	OUTPUT RPM	858	561	438	350	287
	OUTPUT TORQUE IN. LBS.	2800	3291	3534	3740	3866
1150	INPUT HORSEPOWER	29.5	21.7	17.8	15.0	12.5
	OUTPUT RPM	564	369	288	230	189
	OUTPUT TORQUE IN. LBS.	3267	3669	3866	4056	4144
850	INPUT HORSEPOWER	23.8	17.1	13.9	11.6	9.8
	OUTPUT RPM	417	272	213	170	140
	OUTPUT TORQUE IN. LBS.	3564	3905	4085	4245	4364
690	INPUT HORSEPOWER	20.3	14.4	11.7	9.7	8.2
	OUTPUT RPM	338	221	173	138	113
	OUTPUT TORQUE IN. LBS.	3745	4056	4226	4380	4500
100	INPUT HORSEPOWER	4.24	2.87	2.25	1.81	1.49
	OUTPUT RPM	49.0	32.0	25.0	20.0	16.4
	OUTPUT TORQUE IN. LBS.	5398	5592	5620	5658	5680

INPUT RPM		SPEED INCREASER RATIOS				
		1:2.04	1:3.12	1:4.00	1:5.00	1:6.09
1000	INPUT HORSEPOWER	49.4				
	OUTPUT RPM	2043				
	OUTPUT TORQUE IN. LBS.	1524				
850	INPUT HORSEPOWER	42.7	44.7			
	OUTPUT RPM	1737	2650			
	OUTPUT TORQUE IN. LBS.	1551	1064			
540	INPUT HORSEPOWER	28.4	29.7	30.9	26.7	26.5
	OUTPUT RPM	1103	1683	2160	2700	3289
	OUTPUT TORQUE IN. LBS.	1620	1113	902	623	508
300	INPUT HORSEPOWER	16.5	17.3	18.1	15.6	15.5
	OUTPUT RPM	613	935	1200	1500	1827
	OUTPUT TORQUE IN. LBS.	1697	1169	949	655	535
100	INPUT HORSEPOWER	5.86	6.18	6.44	5.57	5.54
	OUTPUT RPM	204	312	400	500	609
	OUTPUT TORQUE IN. LBS.	1807	1248	1014	701	573

Model 85L – Single Reduction

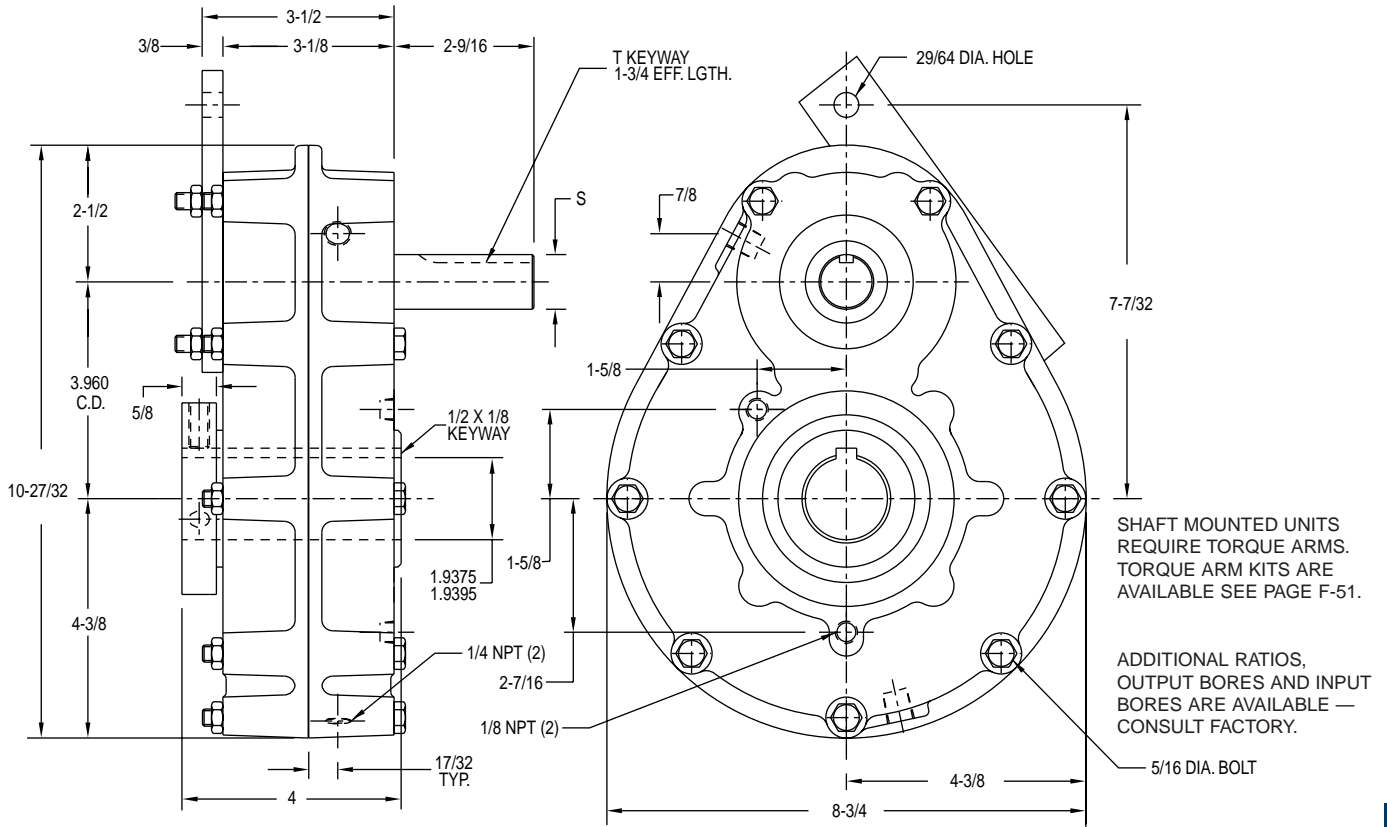

FOR LUBRICATION AND INSTALLATION INSTRUCTIONS - REFER TO SECTION R

DIMENSIONS SHOWN ARE FOR REFERENCE ONLY. CERTIFIED PRINTS ARE AVAILABLE UPON REQUEST.

DRY SHIPPING WEIGHT 40 LBS.

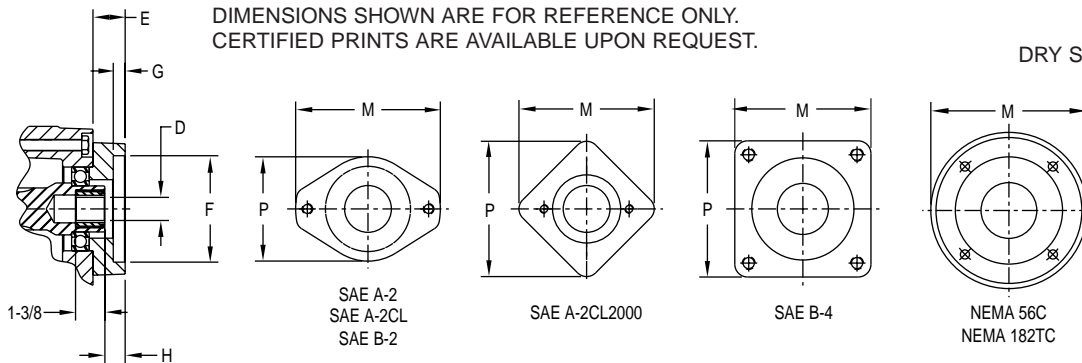

SEE CHART FOR (QTY) J HOLES ON K B.C. FOR EACH FLANGE SIZE

HIGH SPEED SHAFT DIMENSIONS			INPUT BUSHING SIZES					
RATIO	S DIA.	T KEYWAY	D					
2:1, 3:1, 4:1 & 5:1 6:1	1.000/.998 .875/.874	1/4 X 1/8 3/16 X 3/32	.625 DIA. - 3/16 X 3/32 KW	1.125 DIA. - 1/4 X 1/8 KW	1" - 6B SPLINE	14T - 12/24 D.P. SPLINE		
			.875 DIA. - 3/16 X 3/32 KW	1.250 DIA. - 1/4 X 1/8 KW	9T - 16/32 D.P. SPLINE	15T - 16/32 D.P. SPLINE		
			1.000 DIA. - 1/4 X 1/8 KW	1.250 DIA. - 5/16 X 1/8 KW	13T - 16/32 D.P. SPLINE	21T - 16/32 D.P. SPLINE		

FLANGE	E	COUNTERBORE F	G	H	(QTY) J HOLES	B.C. DIA. K	M	P
A-2	1-7/16	3.251 / 3.253	5/16	7/16	(2) 3/8 NC	4-3/16	5-1/8	4-1/16
A-2CL	1-7/16	3.251 / 3.253	3/16	7/16	(2) 1/2 NC	4-3/16	5-1/8	4-1/16
A-2CL2000	1-13/16	3.251 / 3.253	13/32	51/64	(2) 1/2 NC	4-3/16	5-1/2	5-1/2
B-2	1-7/16	4.001 / 4.003	7/16	7/16	(2) 1/2 NC	5-3/4	6-7/8	5-1/4
B-4	1-7/16	4.001 / 4.003	7/16	7/16	(4) 1/2 NC	5	5-1/8	5-1/8
56C	1-5/8	4.502 / 4.504	5/16	5/8	(4) 13/32 DIA.	5-7/8	6-9/16	--
182TC	2-7/16	8.502 / 8.505	5/16	1-7/16	(4) 17/32 DIA.	7-1/4	9-1/8	--

Single Reduction

HUB CITY PARALLEL SHAFT DRIVES

Model 200 - Single Reduction

Features

- ◆ Rugged cast iron housing designed for rigid gear and bearing support.
- ◆ Alloy shafting for greater strength.
- ◆ Tapered roller bearings for endurance and strength.
- ◆ Choice of five (5) standard gear ratios.
- ◆ Heat treated alloy steel gearing for strength and long wear life.
- ◆ Helical gears for greater strength and lower noise level.
- ◆ Heavy-duty industrial seals to keep lubricant in and dirt out.
- ◆ Ductile iron feet provide rigid mounting base.
- ◆ Shaft mount units available. (Style SO.)
- ◆ HUB CITY lubricant recommended. (Refer to Section R)

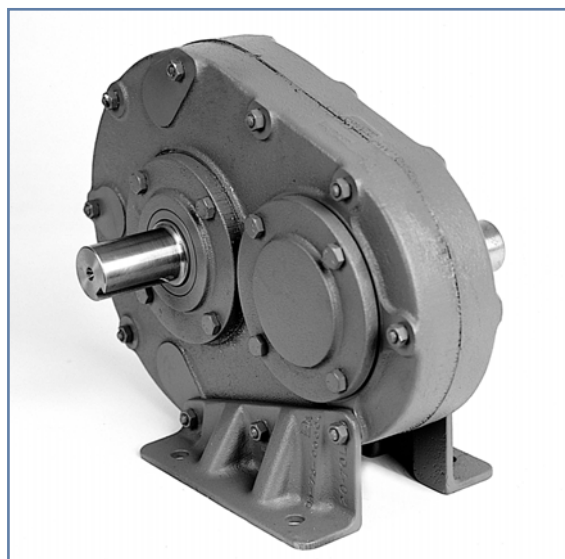

SINGLE REDUCTION UNITS PROVIDE OPPOSITE DIRECTION OUTPUT ROTATION

Rating Table

INPUT RPM		RATIOS				
		1:1 HELICAL	1.5:1 HELICAL	2:1 HELICAL	3:1 HELICAL	4:1 HELICAL
1750	INPUT HORSEPOWER	160	132	105	63	45
	OUTPUT RPM	1750	1167	875	583	438
	OUTPUT TORQUE IN. LBS.	5589	6917	7336	6602	6288
1150	INPUT HORSEPOWER	119	91	71	44	33
	OUTPUT RPM	1150	767	575	383	288
	OUTPUT TORQUE IN. LBS.	6326	7256	7548	7017	7017
850	INPUT HORSEPOWER	89	71	53	32	27
	OUTPUT RPM	850	567	425	283	213
	OUTPUT TORQUE IN. LBS.	6401	7660	7624	6905	7768
690	INPUT HORSEPOWER	75	60	48	28	20
	OUTPUT RPM	690	460	345	230	173
	OUTPUT TORQUE IN. LBS.	6645	7974	8506	7442	7088
100	INPUT HORSEPOWER	13	10	8	4.8	3.5
	OUTPUT RPM	100	67	50	33	25
	OUTPUT TORQUE IN. LBS.	7947	9170	9781	8803	8559

Model 200 - Single Reduction

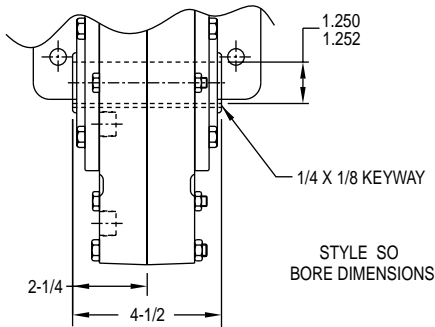
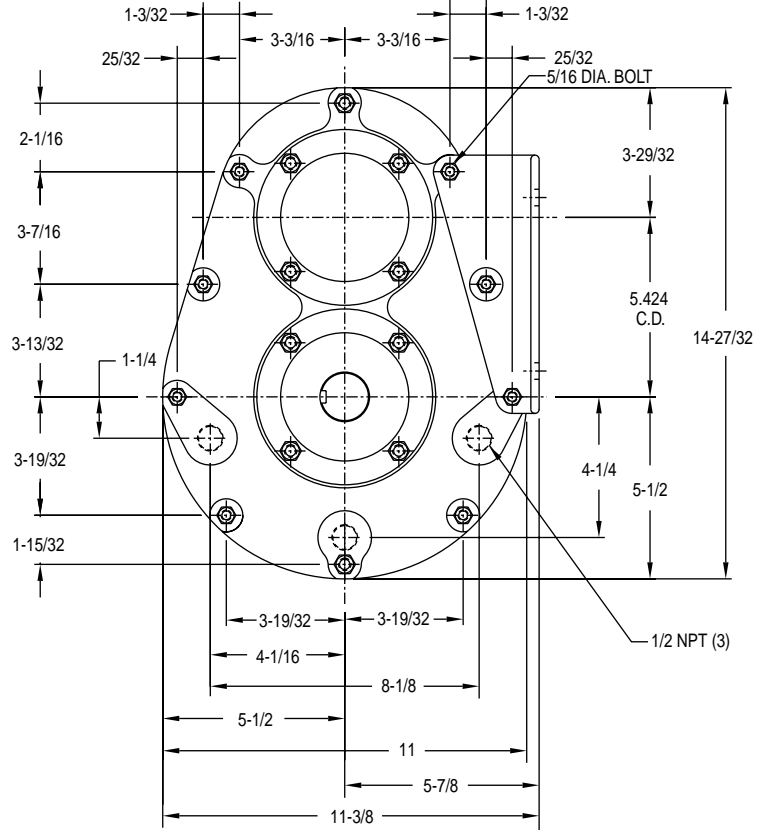
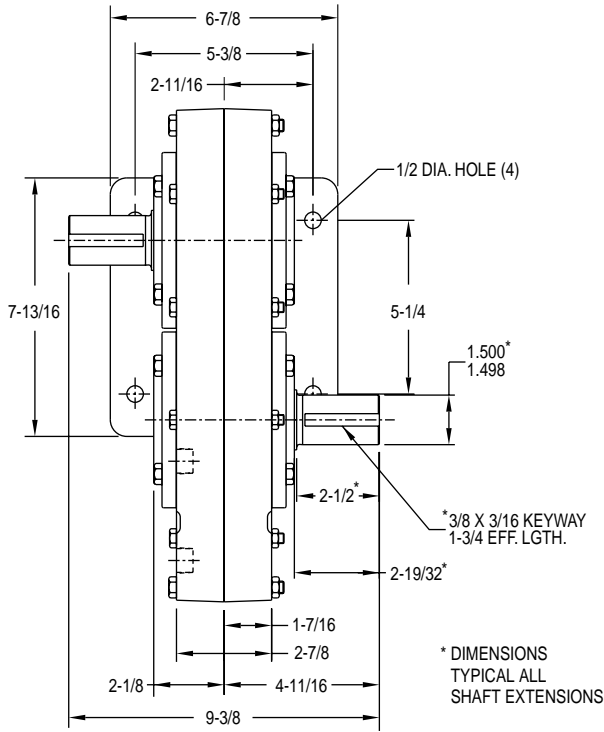

FOR LUBRICATION AND INSTALLATION INSTRUCTIONS - REFER TO SECTION R

SAE A-2, B-2/4, C-2 & C-4 MOTOR FLANGES AVAILABLE ON HIGH SPEED SHAFT AS MODIFIED STANDARD UNITS.

DRY SHIPPING WEIGHT 83 LBS.

OPTIONAL OUTPUT BORE: 1-1/2 WITH 3/8 X 3/16 KEYWAY

DIMENSIONS SHOWN ARE FOR REFERENCE ONLY. CERTIFIED PRINTS ARE AVAILABLE UPON REQUEST.

Standard Styles Available

△ INDICATES HIGH SPEED SHAFT. OTHER STYLES AVAILABLE.

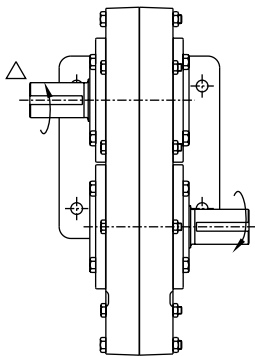

STYLE A

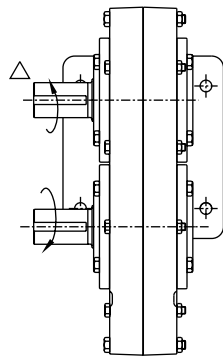

STYLE C

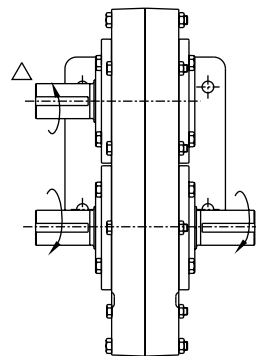

STYLE D0

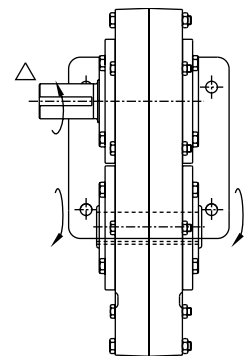

STYLE SO

CONSULT FACTORY FOR VERTICAL SHAFT LUBRICATION RECOMMENDATIONS
INPUT SHAFT CAN BE ROTATED IN EITHER DIRECTION

HUB CITY PARALLEL SHAFT DRIVES

Model 95L – Single Reduction

Features

- ◆ Rugged cast iron housing designed for rigid gear and bearing support.
- ◆ Alloy shafting and sleeves for greater strength.
- ◆ Ball bearings on high speed shaft. Tapered roller bearings on low speed shaft.
- ◆ Choice of five (5) standard gear ratios.
- ◆ Heat treated alloy steel gearing for strength and long wear life.
- ◆ Heavy-duty industrial seals to keep lubricant in and dirt out.
- ◆ Shaft mount design for direct mounting on the drive shaft of equipment to be driven.
- ◆ HUB CITY lubricant recommended. (Refer to Section R)
- ◆ Unit may be operated as a speed increaser or speed reducer.



SINGLE REDUCTION UNITS PROVIDE OPPOSITE DIRECTION OUTPUT ROTATION

Rating Tables

INPUT RPM		SPEED REDUCER RATIOS				
		2.19:1	3.10:1	4.19:1	4.86:1	5.83:1
1750	INPUT HORSEPOWER	63.5	51.2	40.9	36.9	31.8
	OUTPUT RPM	799	565	418	360	300
	OUTPUT TORQUE IN. LBS.	4962	5657	6111	6387	6600
1150	INPUT HORSEPOWER	48.4	37.5	29.5	26.3	22.4
	OUTPUT RPM	525	371	274	237	197
	OUTPUT TORQUE IN. LBS.	5749	6306	6712	6923	7071
850	INPUT HORSEPOWER	38.8	29.5	23.0	20.4	17.4
	OUTPUT RPM	388	274	203	175	146
	OUTPUT TORQUE IN. LBS.	6242	6712	7071	7263	7444
690	INPUT HORSEPOWER	33.0	24.9	19.3	17.1	14.4
	OUTPUT RPM	315	223	165	142	118
	OUTPUT TORQUE IN. LBS.	6543	6972	7312	7500	7615
100	INPUT HORSEPOWER	6.85	4.96	3.68	3.20	2.68
	OUTPUT RPM	45.7	32.3	23.8	20.6	17.1
	OUTPUT TORQUE IN. LBS.	9357	9593	9618	9706	9763

INPUT RPM		SPEED INCREASER RATIOS				
		1:2.19	1:3.10	1:4.19	1:4.86	1:5.83
1000	INPUT HORSEPOWER	103.9				
	OUTPUT RPM	2192				
	OUTPUT TORQUE IN. LBS.	2988				
850	INPUT HORSEPOWER	90.1	86.1			
	OUTPUT RPM	1863	2635			
	OUTPUT TORQUE IN. LBS.	3048	2057			
540	INPUT HORSEPOWER	60.2	57.6	64.3	65.9	63.5
	OUTPUT RPM	1183	1674	2263	2634	3150
	OUTPUT TORQUE IN. LBS.	3204	2166	1792	1583	1270
300	INPUT HORSEPOWER	35.3	33.8	37.4	38.8	37.4
	OUTPUT RPM	658	930	1256	1457	1750
	OUTPUT TORQUE IN. LBS.	3384	2291	1898	1678	1347
100	INPUT HORSEPOWER	12.70	12.20	13.70	14.10	13.50
	OUTPUT RPM	219	310	419	486	583
	OUTPUT TORQUE IN. LBS.	3645	2476	2055	1818	1461

Model 95L – Single Reduction

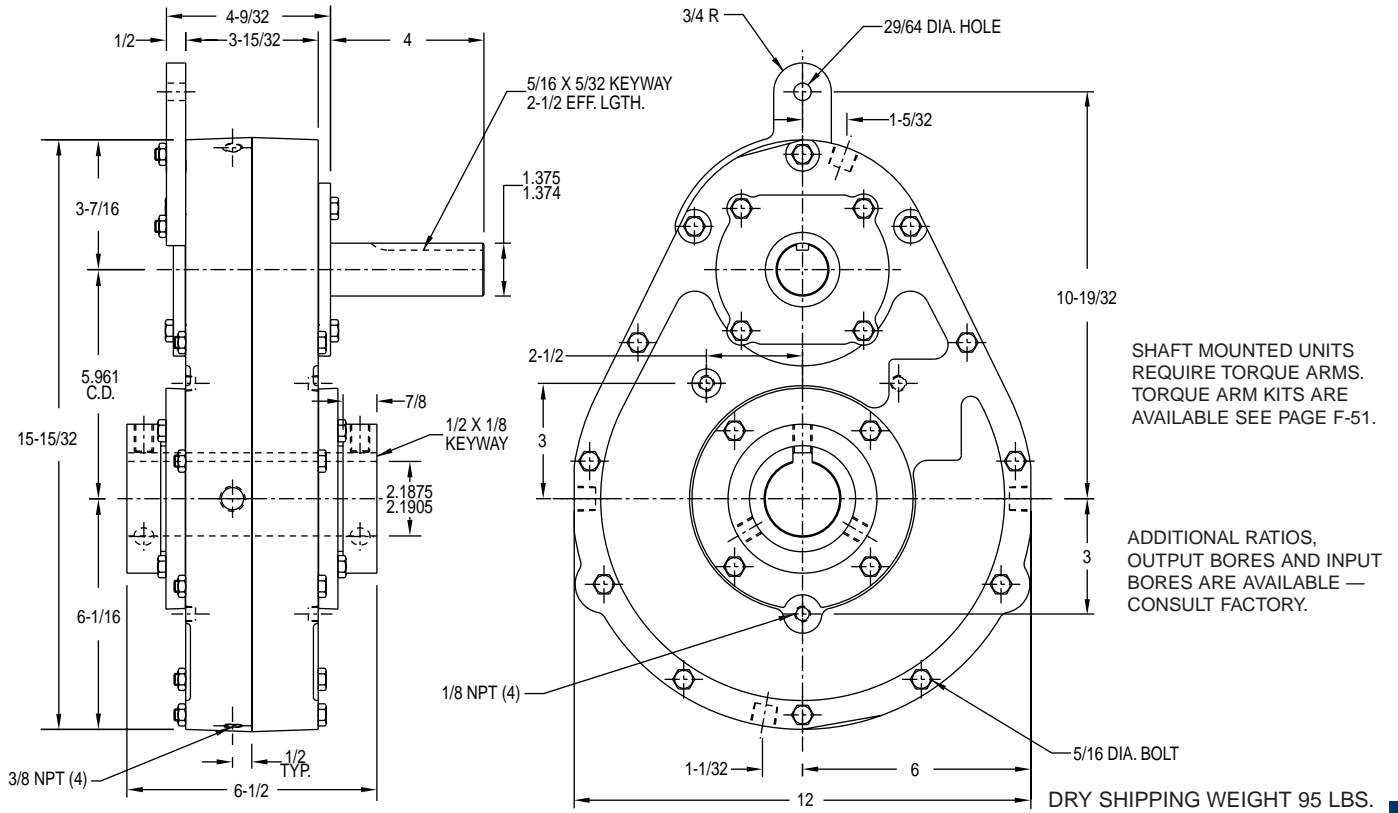

FOR LUBRICATION AND INSTALLATION INSTRUCTIONS - REFER TO SECTION R

DIMENSIONS SHOWN ARE FOR REFERENCE ONLY. CERTIFIED PRINTS ARE AVAILABLE UPON REQUEST.

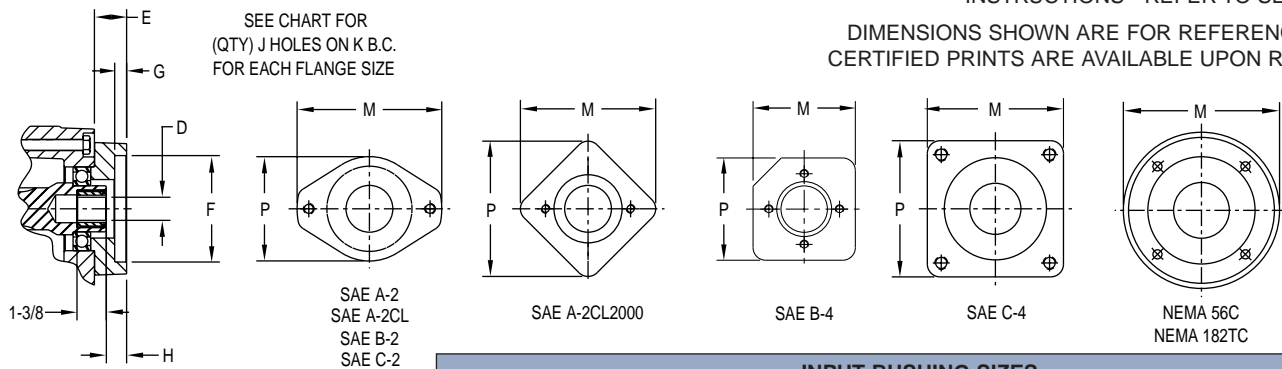

INPUT BUSHING SIZES			
D			
.625 DIA. - 3/16 X 3/32 KW	1.125 DIA. - 1/4 X 1/8 KW	1" - 6B SPLINE	14T - 12/24 D.P. SPLINE
.875 DIA. - 3/16 X 3/32 KW	1.250 DIA. - 1/4 X 1/8 KW	9T - 16/32 D.P. SPLINE	15T - 16/32 D.P. SPLINE
1.000 DIA. - 1/4 X 1/8 KW	1.250 DIA. - 5/16 X 1/8 KW	13T - 16/32 D.P. SPLINE	21T - 16/32 D.P. SPLINE

FLANGE	E	COUNTERBORE F	G	H	(QTY) J HOLES	B.C. DIA. K	M	P
A-2	1-7/16	3.251 / 3.253	5/16	7/16	(2) 3/8 NC	4-3/16	6-7/8	5-1/4
A-2CL	1-7/16	3.251 / 3.253	3/16	7/16	(2) 1/2 NC	4-3/16	6-7/8	5-1/4
A-2CL2000	1-13/16	3.251 / 3.253	13/32	51/64	(2) 1/2 NC	4-3/16	5-1/2	5-1/2
B-2	1-7/16	4.001 / 4.004	15/32	7/16	(2) 1/2 NC	5-3/4	6-7/8	5-1/4
B-4	1-7/16	4.001 / 4.004	7/16	7/16	(4) 1/2 NC	5	6-1/16	6-1/16
C-2	1-7/8	5.001 / 5.004	17/32	7/8	(2) 5/8 NC	7-1/8	8-1/2	5-15/16
C-4	1-7/8	5.001 / 5.004	17/32	7/8	(4) 1/2 NC	6-3/8	6-1/16	6-1/16
56C	1-5/8	4.502 / 4.504	5/16	5/8	(4) 13/32 DIA.	5-7/8	6-9/16	--
182TC	2-7/16	8.502 / 8.505	5/16	1-7/16	(4) 17/32 DIA.	7-1/4	9-1/8	--

HUB CITY PARALLEL SHAFT DRIVES

Model 95H - Single Reduction

Features

- ◆ Rugged cast iron housing designed for rigid gear and bearing support.
- ◆ Alloy shafting and sleeves for greater strength.
- ◆ Tapered roller bearings on all shafts.
- ◆ Choice of four (4) standard gear ratios.
- ◆ Heat treated alloy steel gearing for strength and long wear life.
- ◆ Helical gears for greater strength and lower noise level.
- ◆ Heavy-duty industrial seals to keep lubricant in and dirt out.
- ◆ Shaft mount design for direct mounting on the drive shaft of equipment to be driven.
- ◆ HUB CITY lubricant recommended. (Refer to Section R)
- ◆ Unit may be operated as a speed increaser or speed reducer.



SINGLE REDUCTION UNITS PROVIDE OPPOSITE DIRECTION OUTPUT ROTATION

Rating Tables

Input RPM		SPEED REDUCER RATIOS			
		2.07:1	3.05:1	3.94:1	4.93:1
1750	INPUT HORSEPOWER	144.4	111.1	88.63	64.3
	OUTPUT RPM	846	575	444	355
	OUTPUT TORQUE IN. LBS.	10756	12188	12590	11433
1150	INPUT HORSEPOWER	99.4	76.2	60.6	43.9
	OUTPUT RPM	555	378	291	233
	OUTPUT TORQUE IN. LBS.	11265	12713	13095	11863
850	INPUT HORSEPOWER	75.6	57.8	45.9	33.2
	OUTPUT RPM	410	279	215	172
	OUTPUT TORQUE IN. LBS.	11602	13058	13423	12142
690	INPUT HORSEPOWER	62.6	47.7	37.9	33.2
	OUTPUT RPM	333	226	175	140
	OUTPUT TORQUE IN. LBS.	11820	13279	13636	12319
100	INPUT HORSEPOWER	9.46	7.44	5.92	4.33
	OUTPUT RPM	48	33	25	20
	OUTPUT TORQUE IN. LBS.	13065	14628	14926	13464

Input RPM		SPEED INCREASER RATIOS			
		1:2.07	1:3.05	1:3.94	1:4.93
1000	INPUT HORSEPOWER	167.2			
	OUTPUT RPM	2069			
	OUTPUT TORQUE IN. LBS.	5094			
850	INPUT HORSEPOWER	145.1	157.2		
	OUTPUT RPM	1759	2588		
	OUTPUT TORQUE IN. LBS.	5195	3826		
540	INPUT HORSEPOWER	96.8	105.2	105.7	93.9
	OUTPUT RPM	1117	1644	2130	2664
	OUTPUT TORQUE IN. LBS.	5460	4029	3127	2220
300	INPUT HORSEPOWER	56.8	61.8	62.2	55.3
	OUTPUT RPM	620	913	1183	1479
	OUTPUT TORQUE IN. LBS.	5764	4261	3311	2353
100	INPUT HORSEPOWER	20.4	22.3	22.5	19.9
	OUTPUT RPM	207	304	394	493
	OUTPUT TORQUE IN. LBS.	6207	4603	3583	2550

Model 95H - Single Reduction

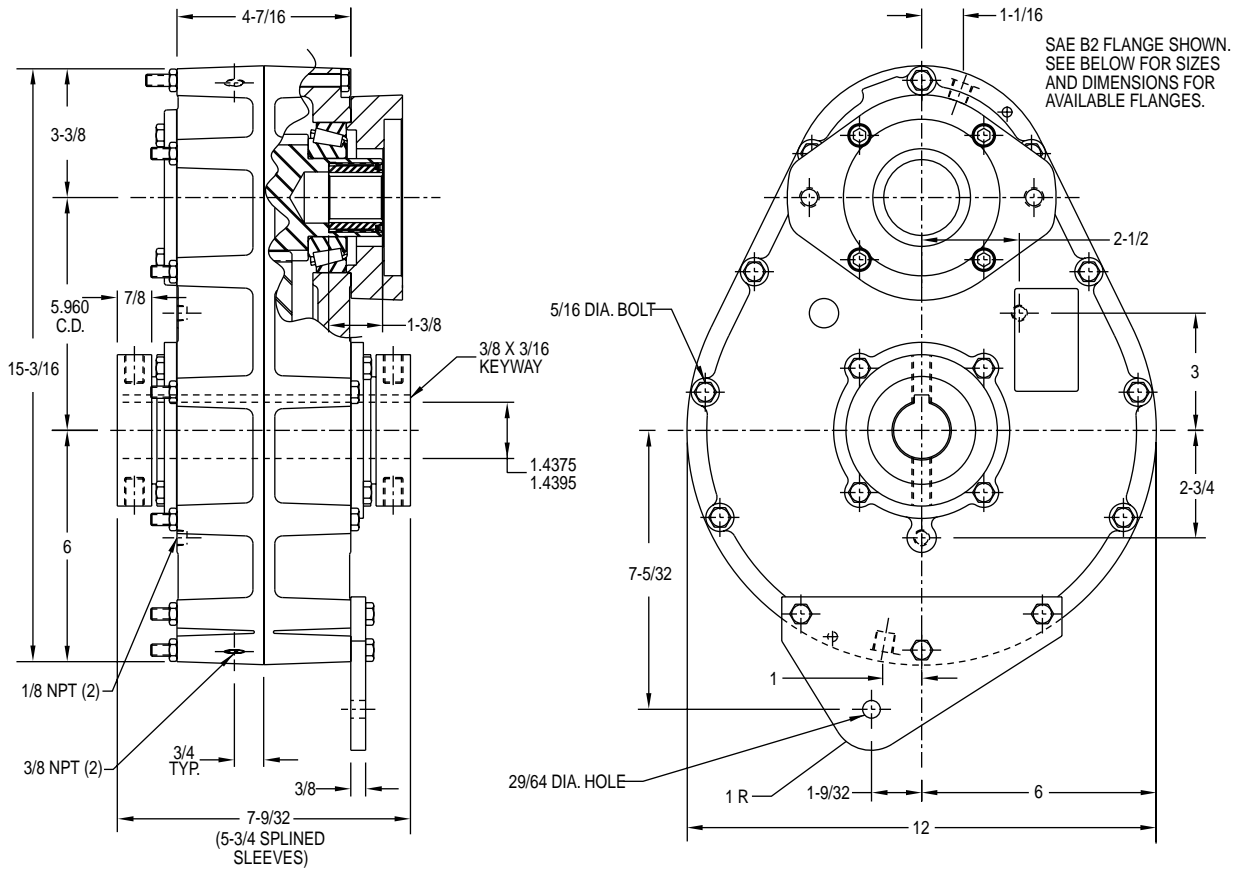

FOR LUBRICATION AND INSTALLATION INSTRUCTIONS - REFER TO SECTION R

DIMENSIONS SHOWN ARE FOR REFERENCE ONLY. CERTIFIED PRINTS ARE AVAILABLE UPON REQUEST.

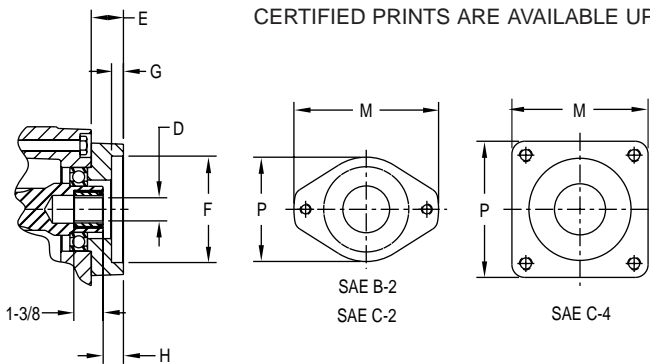

SHAFT MOUNTED UNITS REQUIRE TORQUE ARMS. TORQUE ARM KITS ARE AVAILABLE SEE PAGE F-51.

ADDITIONAL RATIOS, OUTPUT BORES AND INPUT BORES ARE AVAILABLE — CONSULT FACTORY.

SEE CHART FOR (QTY) J HOLES ON K B.C. FOR EACH FLANGE SIZE

DRY SHIPPING WEIGHT 95 LBS.

INPUT BUSHING SIZES			
D			
1.000 DIA. - 1/4 X 1/8 KW	1.250 DIA. - 5/16 X 1/8 KW	13T - 16/32 D.P. SPLINE	21T - 16/32 D.P. SPLINE
1.125 DIA. - 1/4 X 1/8 KW	1" - 6B SPLINE	14T - 12/24 D.P. SPLINE	
1.250 DIA. - 1/4 X 1/8 KW	9T - 16/32 D.P. SPLINE	15T - 16/32 D.P. SPLINE	

FLANGE	E	COUNTERBORE F	G	H	(QTY) J HOLES	B.C. DIA. K	M	P
B-2	1-5/16	4.001 / 4.004	15/32	33/64	(2) 1/2 NC	5-3/4	6-7/8	5-1/4
C-2	1-3/4	5.001 / 5.004	17/32	61/64	(2) 5/8 NC	7-1/8	8-1/2	5-15/16
C-4	1-3/4	5.001 / 5.004	17/32	61/64	(4) 1/2 NC	6-3/8	6-1/16	6-1/16

Single Reduction

HUB CITY PARALLEL SHAFT DRIVES

Model 290 - Single Reduction

Features

- ◆ Rugged cast iron housing designed for rigid gear and bearing support.
- ◆ Tapered roller bearings for endurance and strength.
- ◆ Choice of six (6) standard gear ratios.
- ◆ Case carburized alloy steel gearing for strength and long wear life.
- ◆ Helical gears for greater strength and lower noise level.
- ◆ Heavy-duty industrial seals to keep lubricant in and dirt out.
- ◆ Heat treated alloy steel shafting for greater strength and wear resistance.

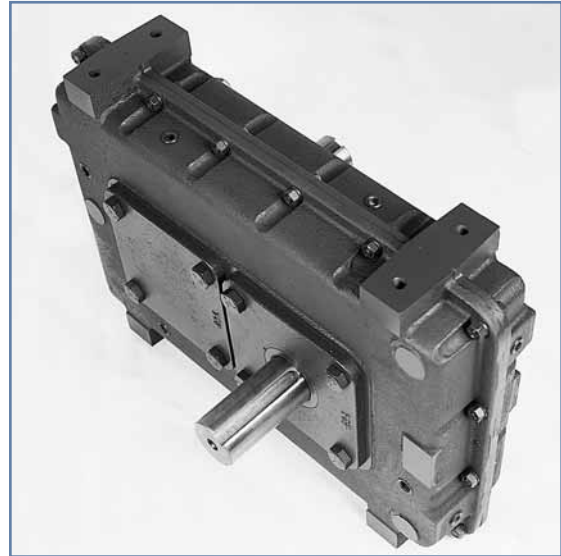

SINGLE REDUCTION UNITS PROVIDE OPPOSITE DIRECTION OUTPUT ROTATION

Rating Table

INPUT RPM		RATIOS					
		1:1 HELICAL	1.5:1 HELICAL	2:1 HELICAL	3:1 HELICAL	4:1 HELICAL	5:1 HELICAL
2400	INPUT HORSEPOWER	530.1	418.4	357.1	262.6	220.1	171.5
	OUTPUT RPM	2400	1600	1200	800	600	480
	OUTPUT TORQUE IN. LBS.	13920	16481.1	18754.6	20688.5	23117	22523.3
	(*) INPUT O.H.L.	740	746	982	1170	1212	1309
	(*) OUTPUT O.H.L.	695	1022	1188	1625	1790	2259
1750	INPUT HORSEPOWER	405.8	319.4	272	199.3	166.6	129.6
	OUTPUT RPM	1750	1166.7	875	583.3	437.5	350
	OUTPUT TORQUE IN. LBS.	14613.6	17254.4	19590.6	21535.5	24000	23334.7
	(*) INPUT O.H.L.	959	974	1185	1343	1392	1485
	(*) OUTPUT O.H.L.	903	1255	1457	1944	2145	2593
1150	INPUT HORSEPOWER	282.7	221.8	188.3	137.4	114.4	88.8
	OUTPUT RPM	1150	766.7	575	383.3	287.5	230
	OUTPUT TORQUE IN. LBS.	15495.4	18229.7	20637.9	22585.7	25086.4	24326.6
	(*) INPUT O.H.L.	1308	1340	1510	1620.7	1680	1765
	(*) OUTPUT O.H.L.	1237	1654	1890	2456	2715	3130
850	INPUT HORSEPOWER	217.1	169.8	143.9	104.7	87	67.41
	OUTPUT RPM	850	566.7	425	263.3	212.5	170
	OUTPUT TORQUE IN. LBS.	16095.4	18888	21340.4	23283.4	25802.9	24976.9
	(*) INPUT O.H.L.	1528	1582	1736	1851	1909	2004
	(*) OUTPUT O.H.L.	1521	1980	2252	2834	3107	3493
690	INPUT HORSEPOWER	180.5	141	119.3	86.6	71.2	55.6
	OUTPUT RPM	690	460	345	230	172.5	138
	OUTPUT TORQUE IN. LBS.	16490.2	19318.8	21798.1	23734.9	26000	25394.5
	(*) INPUT O.H.L.	1681	1751	1894	2012	2068	2170
	(*) OUTPUT O.H.L.	1740	2232	2532	3126	3410	3773
300	INPUT HORSEPOWER	85.2	66.1	55.7	40.1	30.9	24.8
	OUTPUT RPM	300	200	150	100	75	60
	OUTPUT TORQUE IN. LBS.	17892.4	20833.5	23394.9	25292.2	26000	26000
	(*) INPUT O.H.L.	2432	2555	2664	2798	2850	2978
	(*) OUTPUT O.H.L.	2818	3383	3751	4444	4857	5000
100	INPUT HORSEPOWER	30.6	23.4	19.8	13.8	10.3	8.3
	OUTPUT RPM	100	66.7	50	33.3	25	20
	OUTPUT TORQUE IN. LBS.	19298.8	22124	24950.8	26000	26000	26000
	(*) INPUT O.H.L.	3853	4007	4120	4273	4336	4476
	(*) OUTPUT O.H.L.	4355	5000	5000	5000	5000	5000
WR ² Referred to: (LBS.IN ²)	HIGH SPEED SHAFT	566.8	842.1	1112.2	1839.2	2027.7	2410.2
	LOW SPEED SHAFT	566.8	374.3	278	182.1	126.7	96.4

(*) OVERHUNG LOAD (LBS) AT CENTER OF SHAFT EXTENSIONS

Model 290 - Single Reduction

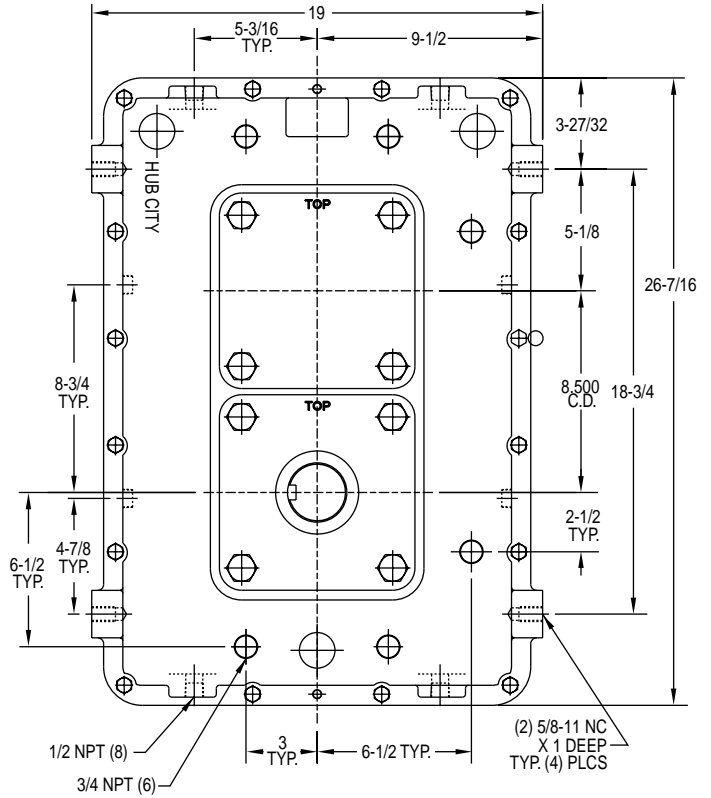
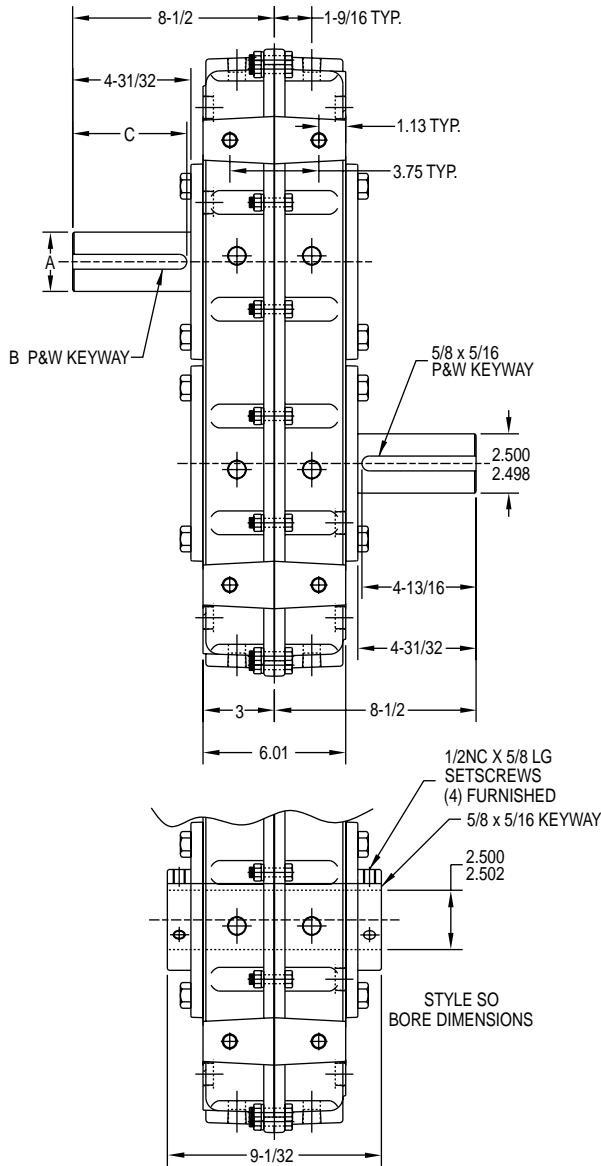

HIGH SPEED SHAFT DIMENSIONS			
RATIO	A	B	C
1:1, 1.5:1, 2:1 & 3:1	2.500/2.498	5/8 X 5/16	4-13/16
4:1 & 5:1	1.750/1.748	3/8 X 3/16	4-1/4

FOR LUBRICATION AND INSTALLATION INSTRUCTIONS - REFER TO SECTION R

DRY SHIPPING WEIGHT 335 LBS.

DIMENSIONS SHOWN ARE FOR REFERENCE ONLY. CERTIFIED PRINTS ARE AVAILABLE UPON REQUEST.

△ INDICATES HIGH SPEED SHAFT. OTHER STYLES AVAILABLE.

Standard Styles Available

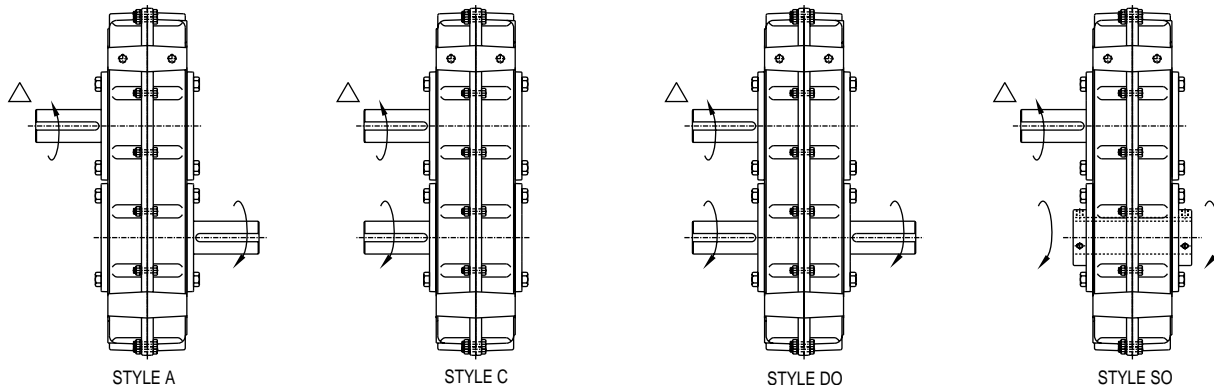

CONSULT FACTORY FOR VERTICAL SHAFT LUBRICATION RECOMMENDATIONS
INPUT SHAFT CAN BE ROTATED IN EITHER DIRECTION

HUB CITY PARALLEL SHAFT DRIVES

Model 52 - Double Reduction

Features

- ◆ Rugged cast iron housing designed for rigid gear and bearing support.
- ◆ Alloy shafting and sleeves for greater strength.
- ◆ Ball bearings on all shafts.
- ◆ Choice of three (3) standard gear ratios.
- ◆ Heat treated alloy steel gearing for strength and long wear life.
- ◆ Heavy-duty industrial seals to keep lubricant in and dirt out.
- ◆ Shaft mount design for direct mounting on the drive shaft of equipment to be driven.
- ◆ HUB CITY lubricant recommended. (Refer to Section R)



DOUBLE REDUCTION UNITS PROVIDE SAME DIRECTION OUTPUT ROTATION

Rating Table

Input RPM		RATIOS		
		15.69:1	19.67:1	25.56:1
1750	INPUT HORSEPOWER	3	2.5	2.1
	OUTPUT RPM	112	89	68
	OUTPUT TORQUE IN. LBS.	1667	1765	1882
1150	INPUT HORSEPOWER	2.2	1.8	1.5
	OUTPUT RPM	73	58	45
	OUTPUT TORQUE IN. LBS.	1858	1927	1991
850	INPUT HORSEPOWER	1.7	1.4	1.1
	OUTPUT RPM	54	43	33
	OUTPUT TORQUE IN. LBS.	1941	2000	2033
690	INPUT HORSEPOWER	1.4	1.2	0.9
	OUTPUT RPM	44	35	27
	OUTPUT TORQUE IN. LBS.	1996	2029	2045
100	INPUT HORSEPOWER	.22	.17	.13
	OUTPUT RPM	6.4	5.1	3.9
	OUTPUT TORQUE IN. LBS.	2100	2100	2100

Model 52 - Double Reduction

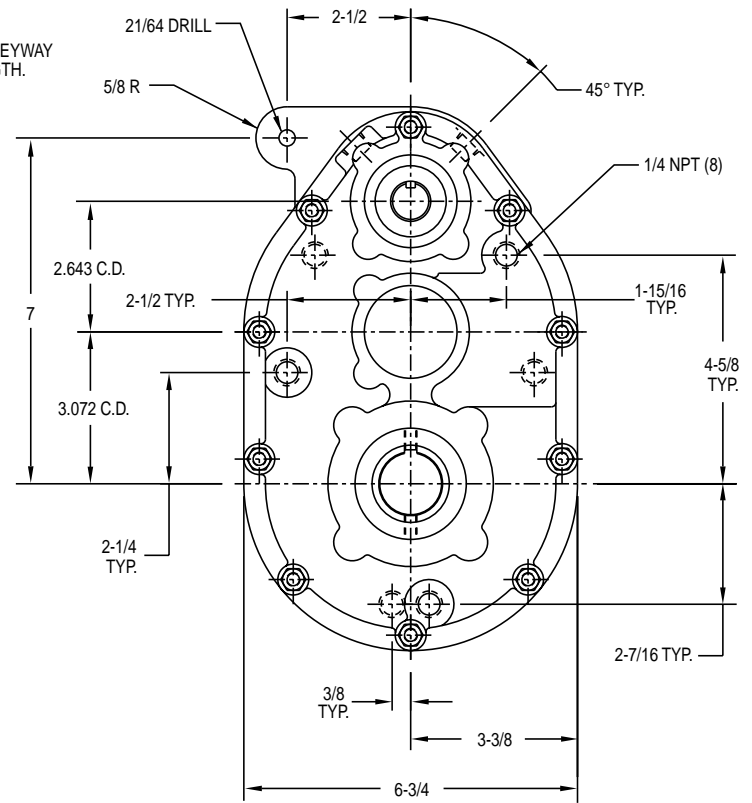
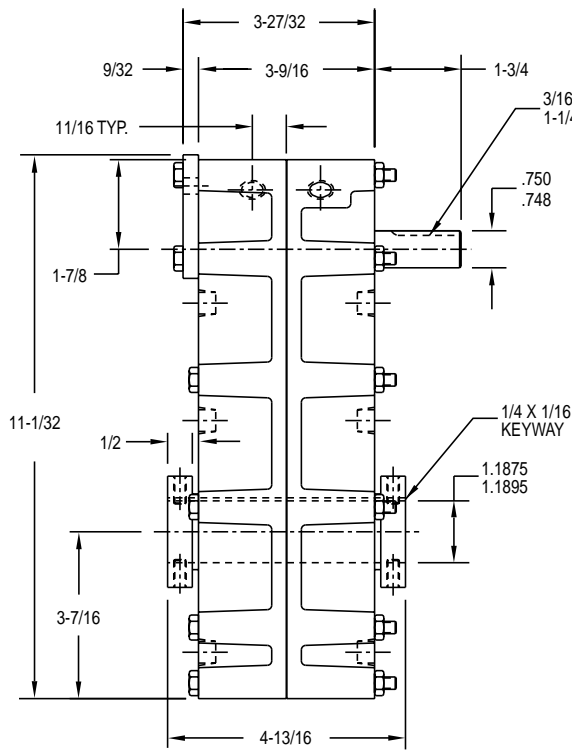

DIMENSIONS SHOWN ARE FOR REFERENCE ONLY. CERTIFIED PRINTS ARE AVAILABLE UPON REQUEST.

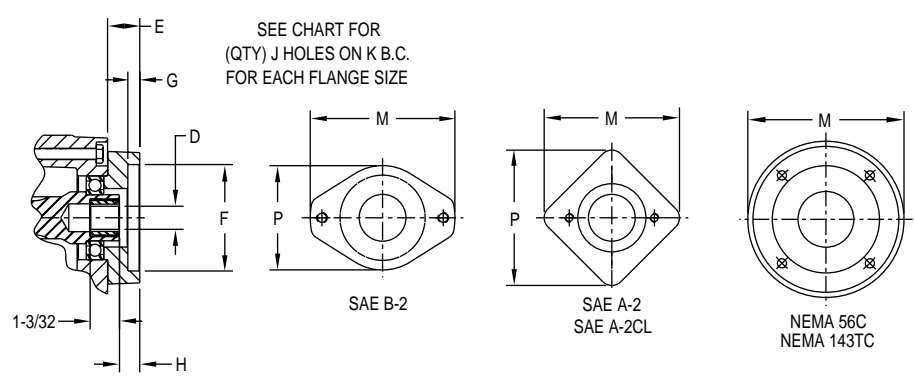

SHAFT MOUNTED UNITS REQUIRE TORQUE ARMS. TORQUE ARM KITS ARE AVAILABLE SEE PAGE F-51.

ADDITIONAL RATIOS, OUTPUT BORES AND INPUT BORES ARE AVAILABLE — CONSULT FACTORY.

FOR LUBRICATION AND INSTALLATION INSTRUCTIONS - REFER TO SECTION R

DRY SHIPPING WEIGHT 25 LBS.

INPUT BUSHING SIZES		
D		
.625 DIA. - 3/16 X 3/32 KW	.875 DIA. - 3/16 X 3/32 KW	1" - 6B SPLINE

FLANGE	E	COUNTERBORE F	G	H	(QTY) J HOLES	B.C. DIA. K	M	P
A-2	1-1/2	3.251 / 3.253	5/16	19/32	(2) 3/8 NC	4-3/16	4-1/2	4-1/2
A-2CL	1-3/4	3.251 / 3.253	3/16	19/32	(2) 1/2 NC	4-3/16	4-1/2	4-1/2
B-2	1-5/8	4.001 / 4.003	7/16	3/4	(2) 1/2 NC	5-3/4	6-7/8	5-1/4
56C	2	4.502 / 4.504	3/16	1-7/32	(4) 13/32 DIA.	5-7/8	6-1/2	--

HUB CITY PARALLEL SHAFT DRIVES

Models 83L & 83S - Double Reduction

Features

- ◆ Rugged cast iron housing designed for rigid gear and bearing support.
- ◆ Alloy shafting and sleeves for greater strength.
- ◆ Ball bearings on all shafts.
- ◆ Choice of four (4) standard gear ratios.
- ◆ Heat treated alloy steel gearing for strength and long wear life.
- ◆ Heavy-duty industrial seals to keep lubricant in and dirt out.
- ◆ Shaft mount design for direct mounting on the drive shaft of equipment to be driven.
- ◆ HUB CITY lubricant recommended. (Refer to Section R)



DOUBLE REDUCTION UNITS PROVIDE SAME DIRECTION OUTPUT ROTATION

Rating Table

Input RPM		RATIOS			
		6.09:1	8.14:1	12.47:1	19.37:1
1750	INPUT HORSEPOWER	17.8	14.0	9.8	7.0
	OUTPUT RPM	287	215	140	90
	OUTPUT TORQUE IN. LBS.	3833	4025	4318	4790
1150	INPUT HORSEPOWER	12.6	9.9	7.1	5.0
	OUTPUT RPM	189	141	92	59
	OUTPUT TORQUE IN. LBS.	4124	4308	4766	5782
850	INPUT HORSEPOWER	9.8	7.8	5.6	3.8
	OUTPUT RPM	140	104	68	44
	OUTPUT TORQUE IN. LBS.	4321	4597	5108	5418
690	INPUT HORSEPOWER	8.2	6.7	4.7	3.2
	OUTPUT RPM	113	85	55	36
	OUTPUT TORQUE IN. LBS.	4481	4872	5253	5502
100	INPUT HORSEPOWER	1.50	1.13	.74	.48
	OUTPUT RPM	16.4	12.3	8.0	5.2
	OUTPUT TORQUE IN. LBS.	5632	5677	5700	5700

Models 83L & 83S - Double Reduction

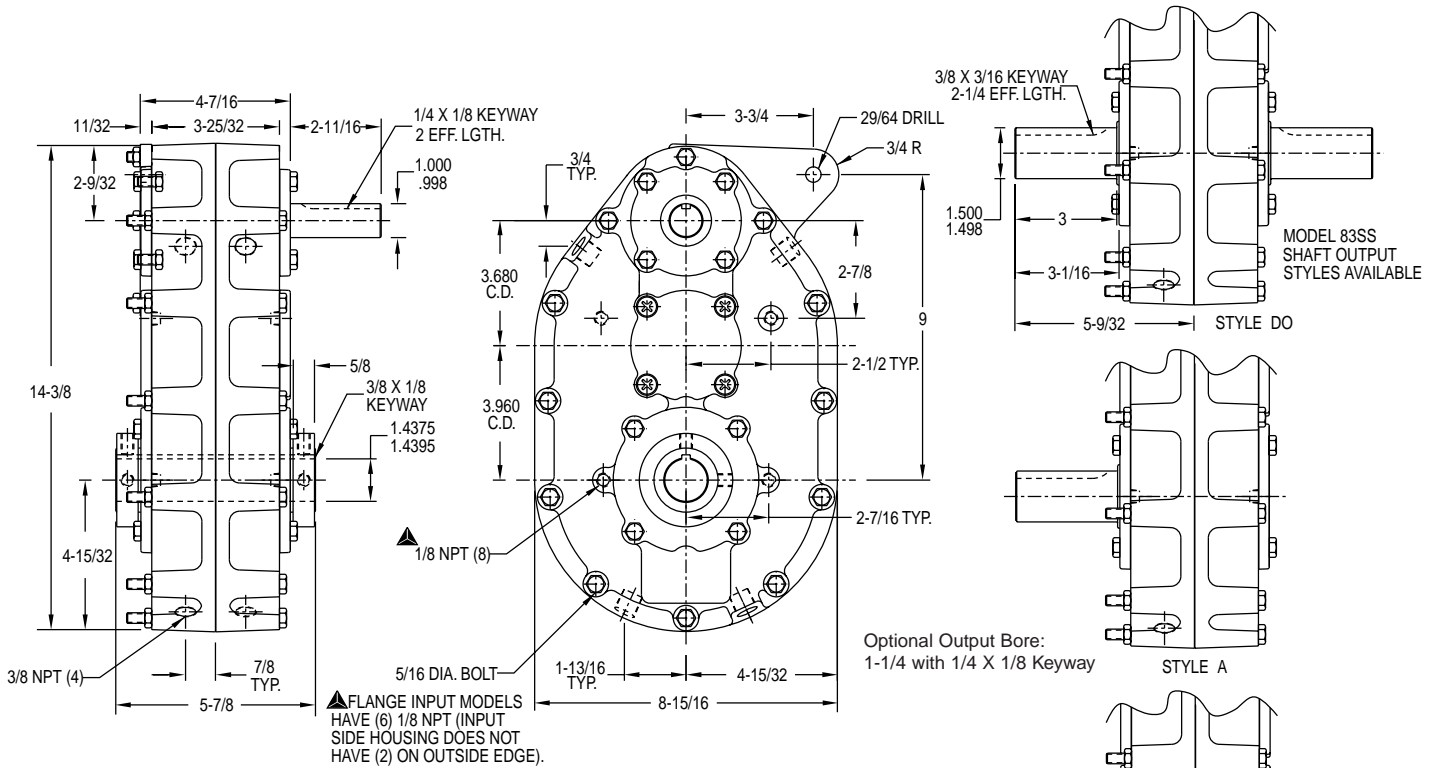

DIMENSIONS SHOWN ARE FOR REFERENCE ONLY. CERTIFIED PRINTS ARE AVAILABLE UPON REQUEST.

FOR LUBRICATION AND INSTALLATION INSTRUCTIONS - REFER TO SECTION R

DRY SHIPPING WEIGHT 60 LBS.

SHAFT MOUNTED UNITS REQUIRE TORQUE ARMS. TORQUE ARM KITS ARE AVAILABLE SEE PAGE F-51.

ADDITIONAL RATIOS, OUTPUT BORES AND INPUT BORES ARE AVAILABLE — CONSULT FACTORY.

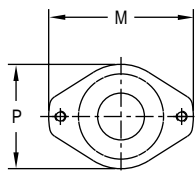
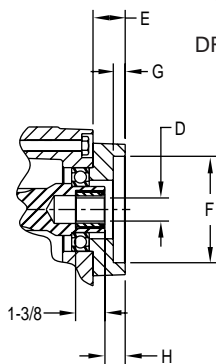

SAE A-2
SAE A-2CL
SAE B-2

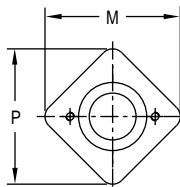

SAE A-2CL2000

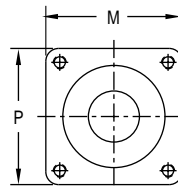

SAE B-4

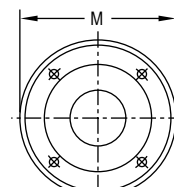

NEMA 56C
NEMA 182TC

SEE CHART FOR (QTY) J HOLES ON K B.C. FOR EACH FLANGE SIZE

INPUT BUSHING SIZES			
D			
.625 DIA. - 3/16 X 3/32 KW	1.125 DIA. - 1/4 X 1/8 KW	1" - 6B SPLINE	14T - 12/24 D.P. SPLINE
.875 DIA. - 3/16 X 3/32 KW	1.250 DIA. - 1/4 X 1/8 KW	9T - 16/32 D.P. SPLINE	15T - 16/32 D.P. SPLINE
1.000 DIA. - 1/4 X 1/8 KW	1.250 DIA. - 5/16 X 1/8 KW	13T - 16/32 D.P. SPLINE	21T - 16/32 D.P. SPLINE

FLANGE	E	COUNTERBORE F	G	H	(QTY) J HOLES	B.C. DIA. K	M	P
A-2	1-7/16	3.251 / 3.253	5/16	7/16	(2) 3/8 NC	4-3/16	5-1/8	4-1/16
A-2CL	1-7/16	3.251 / 3.253	3/16	7/16	(2) 1/2 NC	4-3/16	5-1/8	4-1/16
A-2CL2000	1-13/16	3.251 / 3.253	13/32	51/64	(2) 1/2 NC	4-3/16	5-1/2	5-1/2
B-2	1-7/16	4.001 / 4.003	7/16	7/16	(2) 1/2 NC	5-3/4	6-7/8	5-1/4
B-4	1-7/16	4.001 / 4.003	7/16	7/16	(4) 1/2 NC	5	5-1/8	5-1/8
56C	1-5/8	4.502 / 4.504	5/16	5/8	(4) 13/32 DIA.	5-7/8	6-9/16	--
182TC	2-7/16	8.502 / 8.505	5/16	1-7/16	(4) 17/32 DIA.	7-1/4	9-1/8	--



Double Reduction

HUB CITY PARALLEL SHAFT DRIVES

Model 89 - Double Reduction

Features

- ◆ Rugged cast iron housing designed for rigid gear and bearing support.
- ◆ Alloy shafting and sleeves for greater strength.
- ◆ Ball bearings on all shafts.
- ◆ Choice of four (4) standard gear ratios.
- ◆ Heat treated alloy steel gearing for strength and long wear life.
- ◆ Heavy-duty industrial seals to keep lubricant in and dirt out.
- ◆ Shaft mount design for direct mounting on the drive shaft of equipment to be driven.
- ◆ HUB CITY lubricant recommended. (Refer to Section R)



DOUBLE REDUCTION UNITS PROVIDE SAME DIRECTION OUTPUT ROTATION

Rating Table

Input RPM		RATIOS			
		6.02:1	8.58:1	10.49:1	12.84:1
1750	INPUT HORSEPOWER	25.8	19.2	16.2	13.7
	OUTPUT RPM	291	204	167	136
	OUTPUT TORQUE IN. LBS.	5476	5829	6013	6196
1150	INPUT HORSEPOWER	18.2	13.5	11.5	9.9
	OUTPUT RPM	1911	134	110	90
	OUTPUT TORQUE IN. LBS.	5885	6210	6476	6857
850	INPUT HORSEPOWER	14.1	10.7	9.3	7.9
	OUTPUT RPM	141	99	81	66
	OUTPUT TORQUE IN. LBS.	6174	6689	7096	7338
690	INPUT HORSEPOWER	11.9	9.2	7.8	6.6
	OUTPUT RPM	115	80	66	54
	OUTPUT TORQUE IN. LBS.	6394	7096	7338	7542
100	INPUT HORSEPOWER	2.16	1.54	1.26	1.03
	OUTPUT RPM	16.6	11.7	9.5	7.8
	OUTPUT TORQUE IN. LBS.	8047	8136	8160	8160

Model 89 - Double Reduction

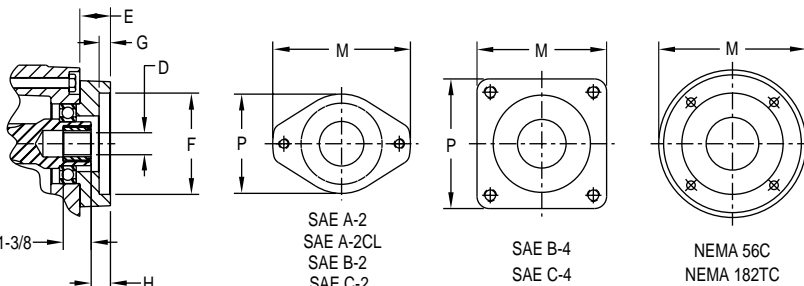
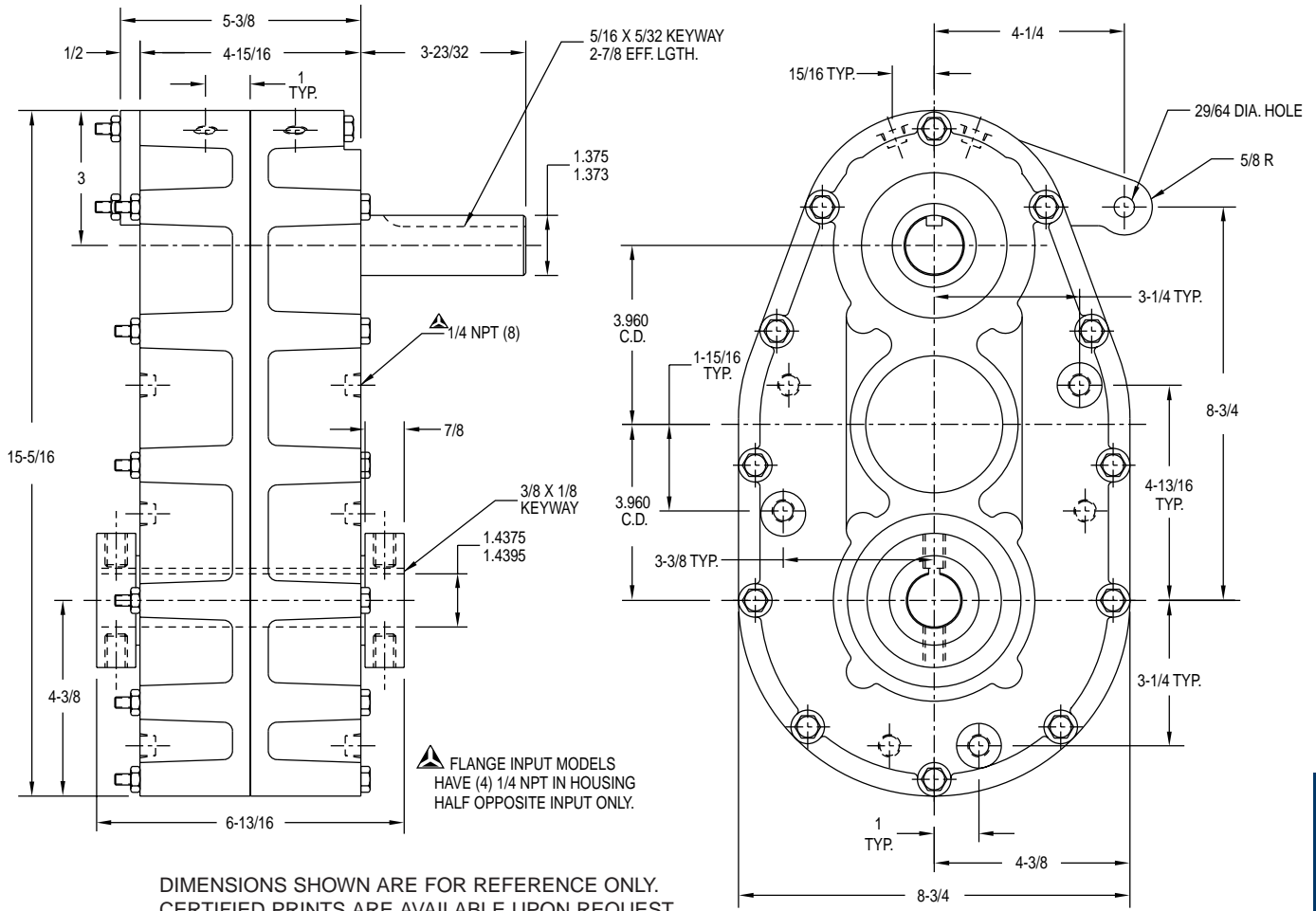

SHAFT MOUNTED UNITS
REQUIRE TORQUE ARMS.
TORQUE ARM KITS ARE
AVAILABLE SEE PAGE F-51.

ADDITIONAL RATIOS,
OUTPUT BORES AND INPUT
BORES ARE AVAILABLE —
CONSULT FACTORY.

FOR LUBRICATION AND INSTALLATION
INSTRUCTIONS - REFER TO SECTION R

DRY SHIPPING WEIGHT 70 LBS.

SEE CHART FOR
(QTY) J HOLES ON K.B.C.
FOR EACH FLANGE SIZE

INPUT BUSHING SIZES			
D			
.625 DIA. - 3/16 X 3/32 KW	1.125 DIA. - 1/4 X 1/8 KW	1" - 6B SPLINE	14T - 12/24 D.P. SPLINE
.875 DIA. - 3/16 X 3/32 KW	1.250 DIA. - 1/4 X 1/8 KW	9T - 16/32 D.P. SPLINE	15T - 16/32 D.P. SPLINE
1.000 DIA. - 1/4 X 1/8 KW	1.250 DIA. - 5/16 X 1/8 KW	13T - 16/32 D.P. SPLINE	21T - 16/32 D.P. SPLINE

FLANGE	E	COUNTERBORE F	G	H	(QTY) J HOLES	B.C. DIA. K	M	P
A-2	1-7/16	3.251 / 3.253	5/16	7/16	(2) 3/8 NC	4-3/16	5-1/8	4-1/16
A-2CL	1-7/16	3.251 / 3.253	3/16	7/16	(2) 1/2 NC	4-3/16	5-1/8	4-1/16
B-2	1-7/16	4.001 / 4.003	7/16	7/16	(2) 1/2 NC	5-3/4	6-7/8	5-1/4
B-4	1-7/16	4.001 / 4.003	7/16	7/16	(4) 1/2 NC	5	5-1/8	5-1/8
C-2	1-7/8	5.001 / 5.003	17/32	31/32	(2) 5/8 NC	7-1/8	8-1/2	5-15/16
C-4	1-7/8	5.001 / 5.003	17/32	31/32	(4) 1/2 NC	6-3/8	6-1/16	6-1/16
56C	1-5/8	4.502 / 4.504	5/16	5/8	(4) 13/32 DIA.	5-7/8	6-9/16	--
182TC	2-7/16	8.501 / 8.504	5/16	1-7/16	(4) 17/32 DIA.	7-1/4	9-1/8	--

F
Double Reduction

HUB CITY PARALLEL SHAFT DRIVES

Model 1 - Double Reduction

Features

- ◆ Rugged cast iron housing designed for rigid gear and bearing support.
- ◆ Alloy shafting and sleeves for greater strength.
- ◆ Ball bearings on all shafts.
- ◆ Choice of five (5) standard gear ratios.
- ◆ Heat treated alloy steel gearing for strength and long wear life.
- ◆ Heavy-duty industrial seals to keep lubricant in and dirt out.
- ◆ Shaft mount design for direct mounting on the drive shaft of equipment to be driven.
- ◆ HUB CITY lubricant recommended. (Refer to Section R)



DOUBLE REDUCTION UNITS PROVIDE SAME DIRECTION OUTPUT ROTATION

Rating Table

Input RPM		RATIOS				
		10.37:1	15.06:1	19.87:1	25.46:1	48.42:1
1750	INPUT HORSEPOWER	11.6	8.4	6.9	5.7	3.3
	OUTPUT RPM	169	116	88	69	36
	OUTPUT TORQUE IN. LBS.	4241	4485	4873	5161	5559
1150	INPUT HORSEPOWER	8.2	6.3	4.9	4.0	2.2
	OUTPUT RPM	111	76	58	45	24
	OUTPUT TORQUE IN. LBS.	4571	5061	5265	5459	5625
850	INPUT HORSEPOWER	6.6	4.8	3.8	3.0	1.6
	OUTPUT RPM	82	56	43	33	18
	OUTPUT TORQUE IN. LBS.	4974	5294	5490	5575	5680
690	INPUT HORSEPOWER	5.6	4.0	3.1	2.5	1.3
	OUTPUT RPM	67	46	35	27	14
	OUTPUT TORQUE IN. LBS.	5179	5444	5565	5608	5714
100	INPUT HORSEPOWER	.90	.62	.47	.37	.19
	OUTPUT RPM	9.6	6.6	5.0	3.9	2.1
	OUTPUT TORQUE IN. LBS.	5760	5760	5760	5760	5760

Model 1 - Double Reduction

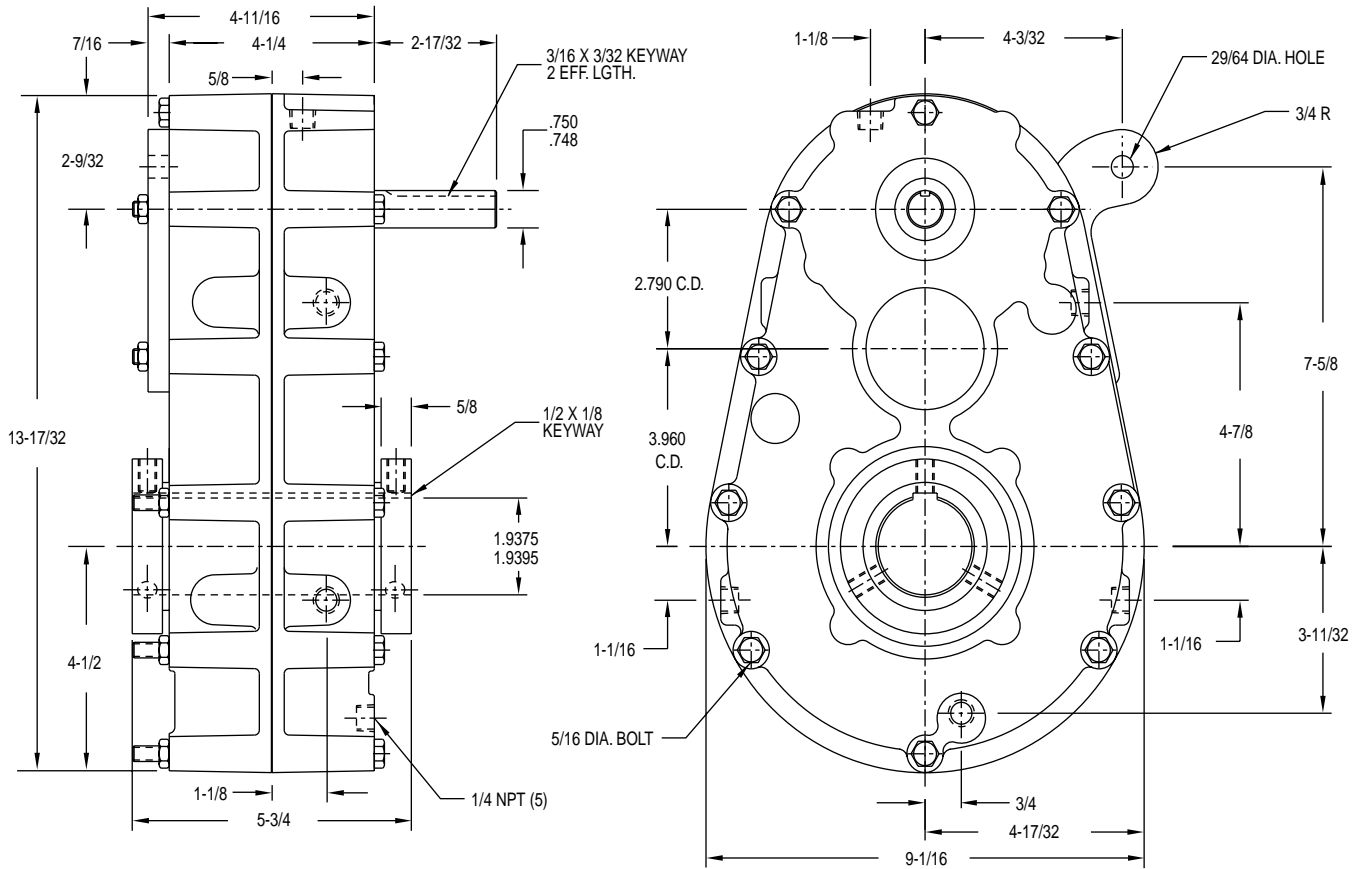

DIMENSIONS SHOWN ARE FOR REFERENCE ONLY.
CERTIFIED PRINTS ARE AVAILABLE UPON REQUEST.

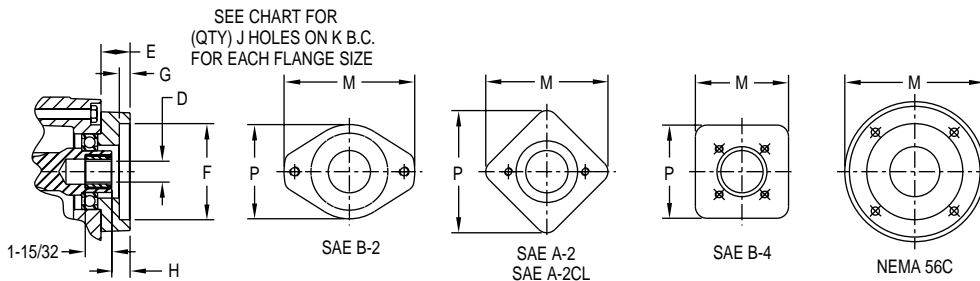

SHAFT MOUNTED UNITS
REQUIRE TORQUE ARMS.
TORQUE ARM KITS ARE
AVAILABLE SEE PAGE F-51.

ADDITIONAL RATIOS,
OUTPUT BORES AND INPUT
BORES ARE AVAILABLE —
CONSULT FACTORY.

DRY SHIPPING WEIGHT 60 LBS.

FOR LUBRICATION AND INSTALLATION
INSTRUCTIONS - REFER TO SECTION R

INPUT BUSHING SIZES			
D			
.625 DIA. - 3/16 X 3/32 KW	.875 DIA. - 3/16 X 3/32 KW	1.000 DIA. - 1/4 X 1/8 KW	1" - 6B SPLINE

FLANGE	E	COUNTERBORE F	G	H	(QTY) J HOLES	B.C. DIA. K	M	P
A-2	1-3/4	3.251 / 3.253	5/16	15/32	(2) 3/8 NC	4-3/16	5-1/2	5-1/2
A-2CL	1-3/4	3.251 / 3.253	3/16	15/32	(2) 1/2 NC	4-3/16	5-1/2	5-1/2
B-2	1-7/8	4.001 / 4.003	7/16	19/32	(2) 1/2 NC	5-3/4	6-7/8	5-1/4
B-4	1-7/8	4.001 / 4.003	7/16	19/32	(4) 1/2 NC	5	6-1/8	6-1/8
56C	2	4.502 / 4.504	3/16	23/32	(4) 13/32 DIA.	5-7/8	6-1/2	--



HUB CITY PARALLEL SHAFT DRIVES

Model 2 - Double Reduction

Features

- ◆ Rugged cast iron housing designed for rigid gear and bearing support.
- ◆ Alloy shafting and sleeves for greater strength.
- ◆ Ball bearings on all shafts.
- ◆ Choice of eight (8) standard gear ratios.
- ◆ Heat treated alloy steel gearing for strength and long wear life.
- ◆ Heavy-duty industrial seals to keep lubricant in and dirt out.
- ◆ Shaft mount design for direct mounting on the drive shaft of equipment to be driven.
- ◆ HUB CITY lubricant recommended. (Refer to Section R)



DOUBLE REDUCTION UNITS PROVIDE SAME DIRECTION OUTPUT ROTATION

Rating Table

Input RPM		RATIOS							
		5.00:1	10.00:1	15.00:1	20.00:1	25.00:1	51.08:1	59.08:1	72.00:1
1750	INPUT HORSEPOWER	21.9	18.5	8.8	7.2	5.8	3.2	2.8	2.3
	OUTPUT RPM	350	175	117	88	70	34	30	24
	OUTPUT TORQUE IN. LBS.	3871	4395	4651	5093	5076	5803	5825	5859
1150	INPUT HORSEPOWER	15.7	8.7	6.5	5.1	4.1	2.1	1.9	1.5
	OUTPUT RPM	230	115	77	58	46	23	19	16
	OUTPUT TORQUE IN. LBS.	4208	4687	5259	5499	5484	5865	5893	5928
850	INPUT HORSEPOWER	12.1	7.1	5.0	3.9	3.1	1.6	1.4	1.1
	OUTPUT RPM	170	85	57	43	34	17	14	12
	OUTPUT TORQUE IN. LBS.	4412	5128	5500	5736	5720	5917	5952	5976
690	INPUT HORSEPOWER	10.2	6.0	4.3	3.2	2.6	1.3	1.1	.9
	OUTPUT RPM	138	69	46	35	28	14	12	10
	OUTPUT TORQUE IN. LBS.	4559	5366	5761	5802	5797	5952	5988	6000
100	INPUT HORSEPOWER	1.90	.97	.65	.49	.39	.19	.16	.13
	OUTPUT RPM	20.0	10.0	6.7	5.0	4.0	2.0	1.7	1.4
	OUTPUT TORQUE IN. LBS.	5882	6000	6000	6000	6000	6000	6000	6000

Model 2 - Double Reduction

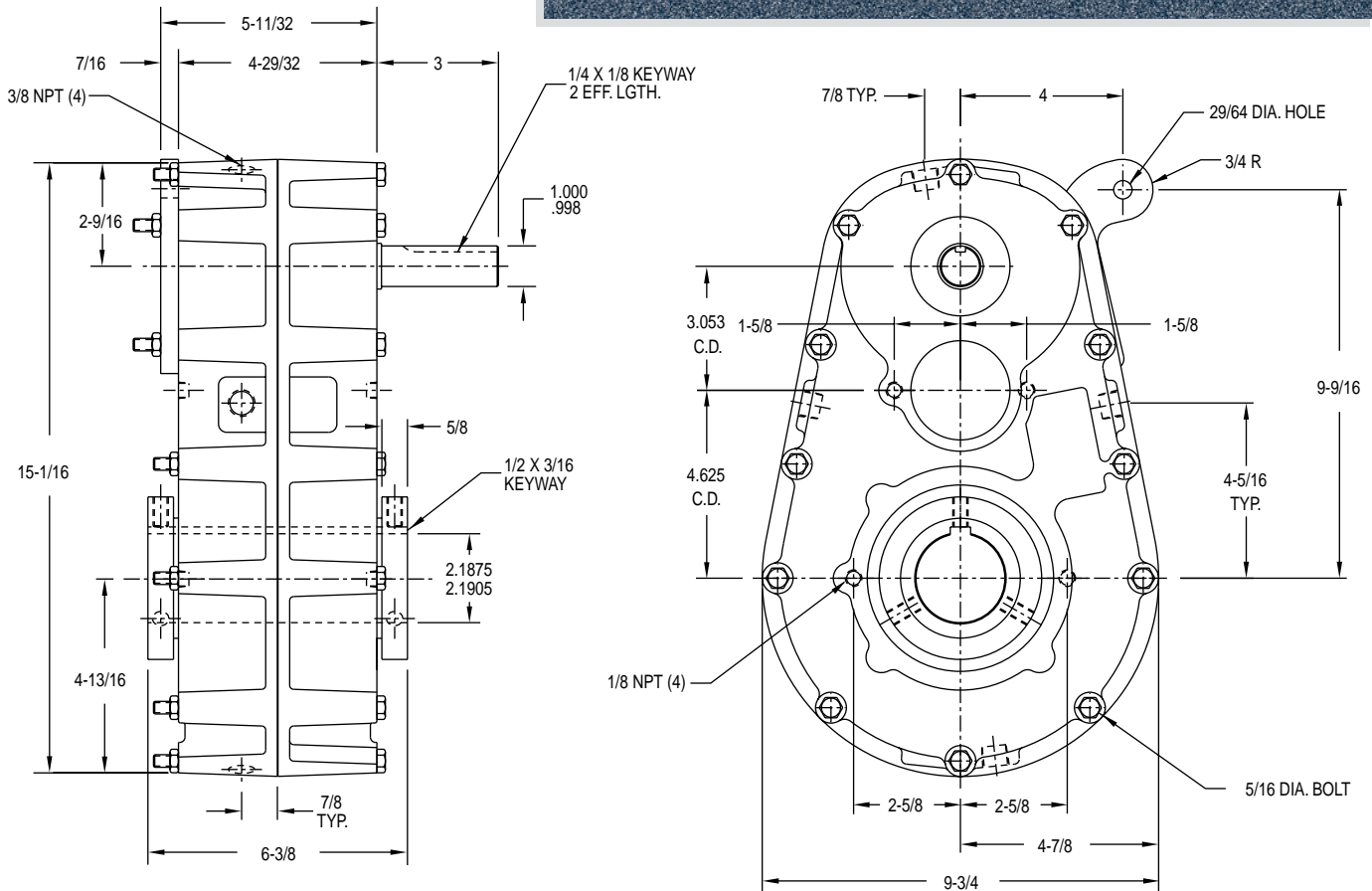

DIMENSIONS SHOWN ARE FOR REFERENCE ONLY.
CERTIFIED PRINTS ARE AVAILABLE UPON REQUEST.

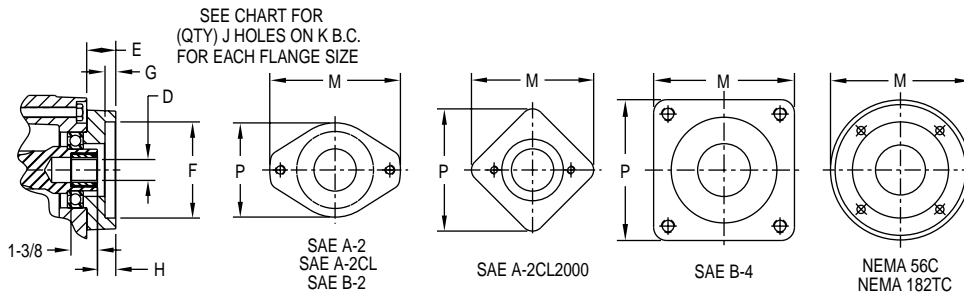

SHAFT MOUNTED UNITS
REQUIRE TORQUE ARMS.
TORQUE ARM KITS ARE
AVAILABLE SEE PAGE F-51.

ADDITIONAL RATIOS,
OUTPUT BORES AND INPUT
BORES ARE AVAILABLE —
CONSULT FACTORY.

FOR LUBRICATION AND INSTALLATION
INSTRUCTIONS - REFER TO SECTION R

DRY SHIPPING WEIGHT 80 LBS.

INPUT BUSHING SIZES

D			
.625 DIA. - 3/16 X 3/32 KW	1.125 DIA. - 1/4 X 1/8 KW	1" - 6B SPLINE	14T - 12/24 D.P. SPLINE
.875 DIA. - 3/16 X 3/32 KW	1.250 DIA. - 1/4 X 1/8 KW	9T - 16/32 D.P. SPLINE	15T - 16/32 D.P. SPLINE
1.000 DIA. - 1/4 X 1/8 KW	1.250 DIA. - 5/16 X 1/8 KW	13T - 16/32 D.P. SPLINE	21T - 16/32 D.P. SPLINE

FLANGE	E	COUNTERBORE F	G	H	(QTY) J HOLES	B.C. DIA. K	M	P
A-2	1-7/16	3.251 / 3.253	5/16	7/16	(2) 3/8 NC	4-3/16	5-1/8	4-1/16
A-2CL	1-7/16	3.251 / 3.253	3/16	7/16	(2) 1/2 NC	4-3/16	5-1/8	4-1/16
A-2CL2000	1-13/16	3.251 / 3.253	13/32	51/64	(2) 1/2 NC	4-3/16	5-1/2	5-1/2
B-2	1-7/16	4.001 / 4.003	7/16	7/16	(2) 1/2 NC	5-3/4	6-7/8	5-1/4
B-4	1-7/16	4.001 / 4.003	7/16	7/16	(4) 1/2 NC	5	5-1/8	5-1/8
56C	1-5/8	4.502 / 4.504	5/16	5/8	(4) 13/32 DIA.	5-7/8	6-9/16	--
182TC	2-7/16	8.502 / 8.505	5/16	1-7/16	(4) 17/32 DIA.	7-1/4	9-1/8	--

F
Double Reduction

HUB CITY PARALLEL SHAFT DRIVES

Model 3 - Double Reduction

Features

- ◆ Rugged cast iron housing designed for rigid gear and bearing support.
- ◆ Alloy shafting and sleeves for greater strength.
- ◆ Ball bearings on all shafts.
- ◆ Choice of eight (8) standard gear ratios.
- ◆ Heat treated alloy steel gearing for strength and long wear life.
- ◆ Heavy-duty industrial seals to keep lubricant in and dirt out.
- ◆ Shaft mount design for direct mounting on the drive shaft of equipment to be driven.
- ◆ HUB CITY lubricant recommended. (Refer to Section R)



DOUBLE REDUCTION UNITS PROVIDE SAME DIRECTION OUTPUT ROTATION

Rating Table

Input RPM		RATIOS							
		4.92:1	10.08:1	15.19:1	25.34:1	31.14:1	40.57:1	44.89:1	63.99:1
1750	INPUT HORSEPOWER	37.2	20.6	14.6	9.5	8.4	6.7	6.1	4.3
	OUTPUT RPM	356	174	115	69	56	43	39	27
	OUTPUT TORQUE IN. LBS.	6452	7336	7813	8460	9191	9532	9624	9737
1150	INPUT HORSEPOWER	26.2	14.5	10.8	6.7	5.8	4.5	4.0	2.9
	OUTPUT RPM	234	114	76	45	37	28	26	18
	OUTPUT TORQUE IN. LBS.	6918	7836	8787	9141	9643	9727	9756	9842
850	INPUT HORSEPOWER	20.5	11.7	8.3	5.2	4.3	3.3	3.0	2.1
	OUTPUT RPM	173	84	56	34	27	21	19	13
	OUTPUT TORQUE IN. LBS.	7331	8576	9191	9533	9737	9794	9823	9950
690	INPUT HORSEPOWER	17.2	9.9	7.0	4.3	3.5	2.7	2.5	1.7
	OUTPUT RPM	140	68	45	27	22	17	15	11
	OUTPUT TORQUE IN. LBS.	7576	8960	9479	9662	9785	9861	9900	9980
100	INPUT HORSEPOWER	3.23	1.61	1.07	.64	.52	.40	.36	.25
	OUTPUT RPM	20.3	9.9	6.6	3.9	3.2	2.5	2.2	1.6
	OUTPUT TORQUE IN. LBS.	9804	10000	10000	10000	10000	10000	10000	10000

Model 3 - Double Reduction

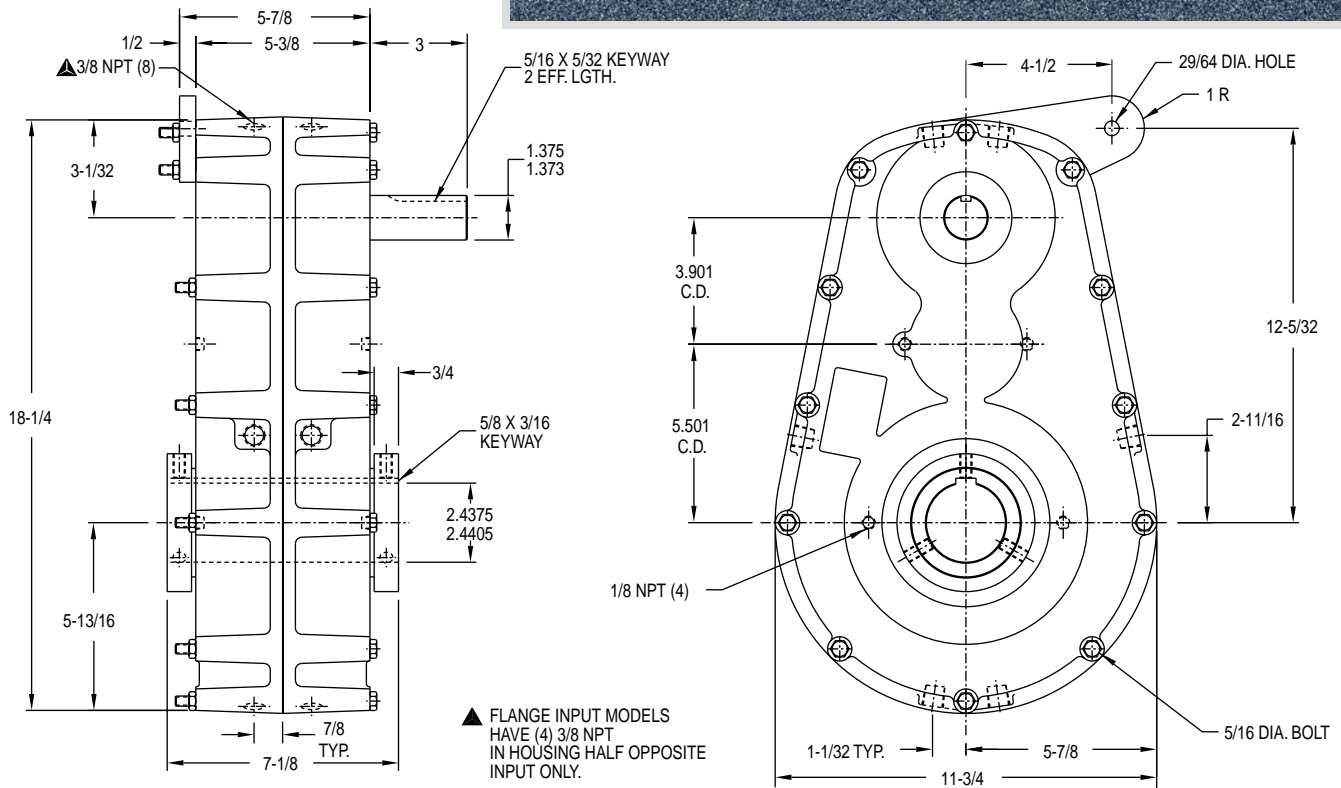

DIMENSIONS SHOWN ARE FOR REFERENCE ONLY.
CERTIFIED PRINTS ARE AVAILABLE UPON REQUEST.

FOR LUBRICATION AND INSTALLATION
INSTRUCTIONS - REFER TO SECTION R

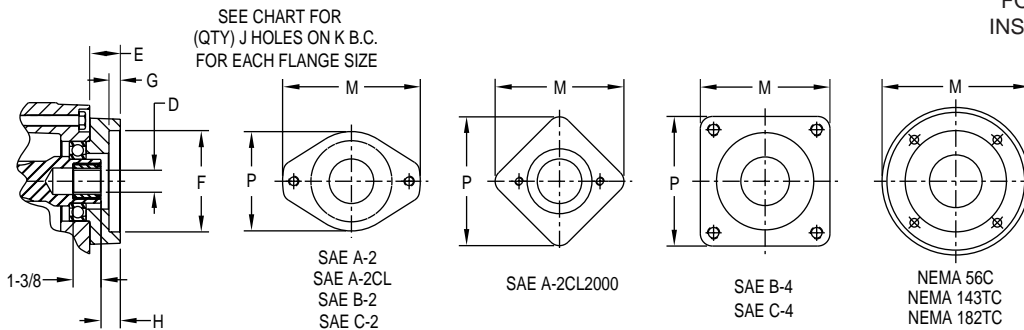

SHAFT MOUNTED UNITS
REQUIRE TORQUE ARMS.
TORQUE ARM KITS ARE
AVAILABLE SEE PAGE F-51.

ADDITIONAL RATIOS,
OUTPUT BORES AND INPUT
BORES ARE AVAILABLE —
CONSULT FACTORY.

DRY SHIPPING WEIGHT 120 LBS.

INPUT BUSHING SIZES

D			
.625 DIA. - 3/16 X 3/32 KW	1.125 DIA. - 1/4 X 1/8 KW	1" - 6B SPLINE	14T - 12/24 D.P. SPLINE
.875 DIA. - 3/16 X 3/32 KW	1.250 DIA. - 1/4 X 1/8 KW	9T - 16/32 D.P. SPLINE	15T - 16/32 D.P. SPLINE
1.000 DIA. - 1/4 X 1/8 KW	1.250 DIA. - 5/16 X 1/8 KW	13T - 16/32 D.P. SPLINE	21T - 16/32 D.P. SPLINE

FLANGE	E	COUNTERBORE F	G	H	(QTY) J HOLES	B.C. DIA. K	M	P
A-2	1-7/16	3.251 / 3.253	5/16	7/16	(2) 3/8 NC	4-3/16	5-1/8	4-1/16
A-2CL	1-7/16	3.251 / 3.253	3/16	7/16	(2) 1/2 NC	4-3/16	5-1/8	4-1/16
A-2CL2000	1-13/16	3.251 / 3.253	13/32	51/64	(2) 1/2 NC	4-3/16	5-1/2	5-1/2
B-2	1-7/16	4.001 / 4.003	7/16	7/16	(2) 1/2 NC	5-3/4	6-7/8	5-1/4
B-4	1-7/16	4.001 / 4.003	7/16	7/16	(4) 1/2 NC	5	5-1/8	5-1/8
C-2	1-7/8	5.001 / 5.003	17/32	7/8	(2) 5/8 NC	7-1/8	8-1/2	6-1/8
C-4	1-7/8	5.001 / 5.003	17/32	7/8	(4) 1/2 NC	6-3/8	6-1/16	6-1/16
56C	1-5/8	4.502 / 4.504	5/16	5/8	(4) 13/32 DIA.	5-7/8	6-9/16	--
143TC	1-5/8	4.502 / 4.504	5/16	5/8	(4) 13/32 DIA.	5-7/8	6-9/16	--
182TC	2-7/16	8.502 / 8.505	5/16	1-7/16	(4) 17/32 DIA.	7-1/4	9-1/8	--

F

Double Reduction

HUB CITY PARALLEL SHAFT DRIVES

Model 4 - Double Reduction

Features

- ◆ Rugged cast iron housing designed for rigid gear and bearing support.
- ◆ Alloy shafting and sleeves for greater strength.
- ◆ Ball bearings on high speed shaft. Tapered roller bearings on low speed shaft.
- ◆ Choice of seven (7) standard gear ratios.
- ◆ Heat treated alloy steel gearing for strength and long wear life.
- ◆ Heavy-duty industrial seals to keep lubricant in and dirt out.
- ◆ Shaft mount design for direct mounting on the drive shaft of equipment to be driven.
- ◆ HUB CITY lubricant recommended. (Refer to Section R)



DOUBLE REDUCTION UNITS PROVIDE SAME DIRECTION OUTPUT ROTATION

Rating Table

Input RPM		RATIOS						
		5.02:1	7.99:1	12.42:1	15.87:1	18.96:1	23.65:1	30.02:1
1750	INPUT HORSEPOWER	49.9	40.1	27.7	22.7	20.0	17.1	13.8
	OUTPUT RPM	350	219	141	110	92	74	58
	OUTPUT TORQUE IN. LBS.	8536	11314	12136	12714	13395	14265	14644
1150	INPUT HORSEPOWER	34.0	28.2	20.0	16.7	14.3	11.9	9.6
	OUTPUT RPM	250	144	93	72	61	49	38
	OUTPUT TORQUE IN. LBS.	8851	12081	13361	14227	14537	15099	15433
850	INPUT HORSEPOWER	25.7	22.2	15.9	12.9	11.0	9.0	7.1
	OUTPUT RPM	170	106	68	54	45	36	28
	OUTPUT TORQUE IN. LBS.	9052	12878	14329	14847	15185	15478	15584
690	INPUT HORSEPOWER	21.1	19.1	13.2	10.8	9.1	7.4	5.8
	OUTPUT RPM	138	86	56	43	36	29	23
	OUTPUT TORQUE IN. LBS.	9155	13646	14713	15272	15463	15584	15660
100	INPUT HORSEPOWER	3.33	3.23	2.03	1.63	1.37	1.1	.86
	OUTPUT RPM	20.0	12.5	8.0	6.3	5.3	4.2	3.3
	OUTPUT TORQUE IN. LBS.	10535	15940	16020	16020	16020	16020	16020

Model 4 - Double Reduction

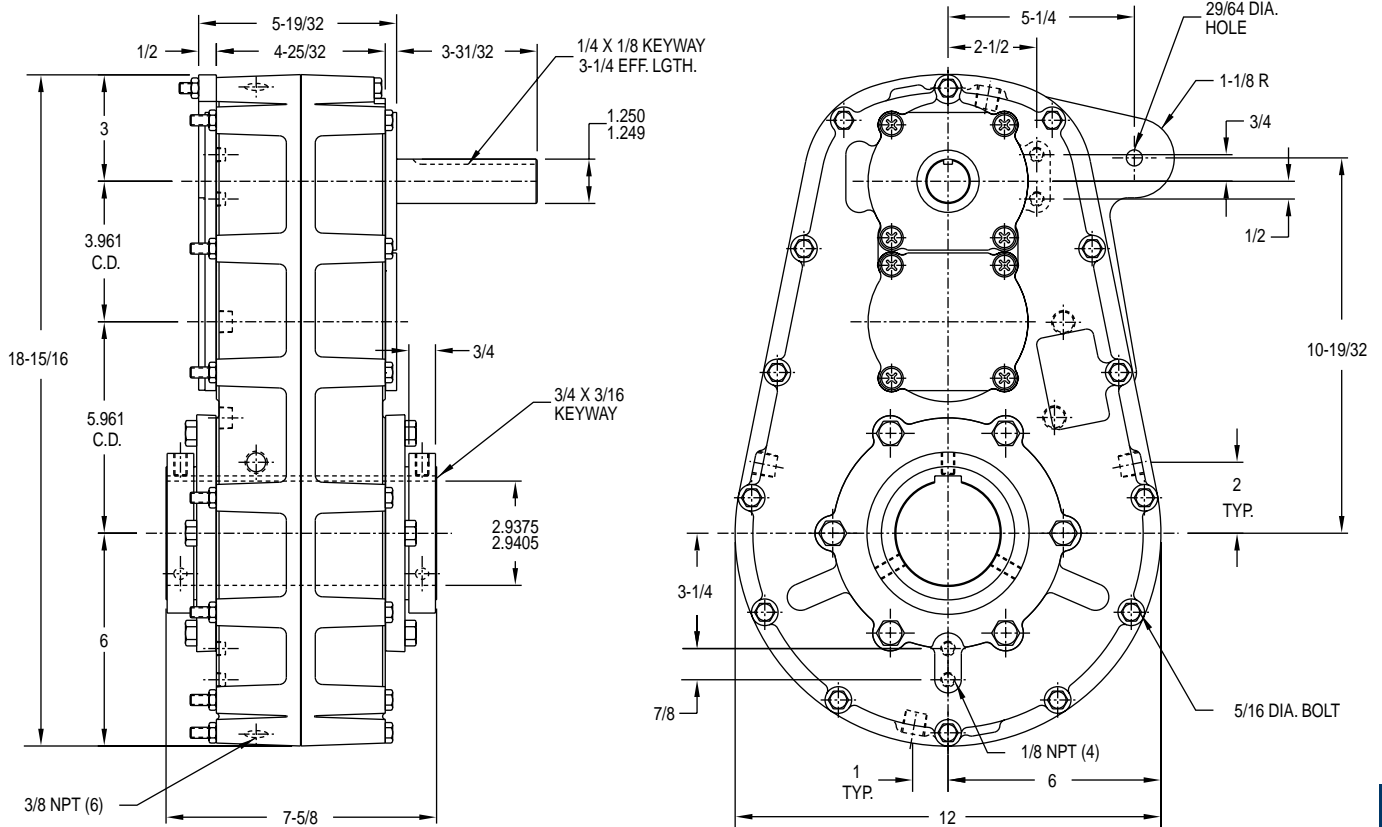

DIMENSIONS SHOWN ARE FOR REFERENCE ONLY. CERTIFIED PRINTS ARE AVAILABLE UPON REQUEST.

SHAFT MOUNTED UNITS REQUIRE TORQUE ARMS. TORQUE ARM KITS ARE AVAILABLE SEE PAGE F-51.

ADDITIONAL RATIOS, OUTPUT BORES AND INPUT BORES ARE AVAILABLE — CONSULT FACTORY.

FOR LUBRICATION AND INSTALLATION INSTRUCTIONS - REFER TO SECTION R

DRY SHIPPING WEIGHT 130 LBS.

SEE CHART FOR (QTY) J HOLES ON K B.C. FOR EACH FLANGE SIZE

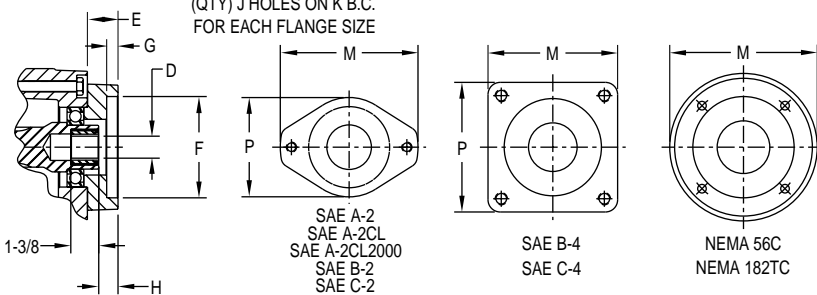

INPUT BUSHING SIZES

D			
.625 DIA. - 3/16 X 3/32 KW	1.125 DIA. - 1/4 X 1/8 KW	1" - 6B SPLINE	14T - 12/24 D.P. SPLINE
.875 DIA. - 3/16 X 3/32 KW	1.250 DIA. - 1/4 X 1/8 KW	9T - 16/32 D.P. SPLINE	15T - 16/32 D.P. SPLINE
1.000 DIA. - 1/4 X 1/8 KW	1.250 DIA. - 5/16 X 1/8 KW	13T - 16/32 D.P. SPLINE	21T - 16/32 D.P. SPLINE

FLANGE	E	COUNTERBORE F	G	H	(QTY) J HOLES	B.C. DIA. K	M	P
A-2	1-1/4	3.251 / 3.253	5/16	51/64	(2) 3/8 NC	4-3/16	6-7/8	5-1/4
A-2CL	1-1/4	3.251 / 3.253	3/16	51/64	(2) 1/2 NC	4-3/16	6-7/8	5-1/4
A-2CL2000	1-1/4	3.251 / 3.253	5/16	51/64	(2) 1/2 NC	4-3/16	6-7/8	5-1/4
B-2	1-1/4	4.001 / 4.003	7/16	51/64	(2) 1/2 NC	5-3/4	6-7/8	5-1/4
B-4	1-1/4	4.001 / 4.003	7/16	51/64	(4) 1/2 NC	5	5-1/8	5-1/8
C-2	1-1/4	5.001 / 5.003	9/16	51/64	(2) 5/8 NC	7-1/8	8-1/2	6-1/8
C-4	1-1/4	5.001 / 5.003	9/16	51/64	(4) 1/2 NC	6-3/8	6-1/8	6-1/8
56C	2	4.502 / 4.504	5/16	1-35/64	(4) 13/32 DIA.	5-7/8	6-9/16	--
182TC	2-9/16	8.501 / 8.504	5/16	2-7/64	(4) 17/32 DIA.	7-1/4	9-1/8	--

F
Double Reduction

HUB CITY PARALLEL SHAFT DRIVES

Model 5 - Double Reduction

Features

- ◆ Rugged cast iron housing designed for rigid gear and bearing support.
- ◆ Alloy shafting and sleeves for greater strength.
- ◆ Ball bearings on all shafts.
- ◆ Choice of seven (7) standard gear ratios.
- ◆ Heat treated alloy steel gearing for strength and long wear life.
- ◆ Heavy-duty industrial seals to keep lubricant in and dirt out.
- ◆ Shaft mount design for direct mounting on the drive shaft of equipment to be driven.
- ◆ HUB CITY lubricant recommended. (Refer to Section R)



DOUBLE REDUCTION UNITS PROVIDE SAME DIRECTION OUTPUT ROTATION

Rating Table

Input RPM		RATIOS						
		5.04:1	10.36:1	15.22:1	19.99:1	25.81:1	29.89:1	49.62:1
1750	INPUT HORSEPOWER	106.6	59.2	42.8	35.4	27.3	25.4	16.2
	OUTPUT RPM	347	169	115	88	68	59	35
	OUTPUT TORQUE IN. LBS.	18968	21649	22969	24957	24873	26800	28406
1150	INPUT HORSEPOWER	76.2	41.9	31.5	25.1	19.4	17.6	10.8
	OUTPUT RPM	228	111	76	58	45	38	23
	OUTPUT TORQUE IN. LBS.	20617	23333	25767	26947	26874	28334	28739
850	INPUT HORSEPOWER	59.0	33.7	24.4	19.4	14.9	13.2	8.0
	OUTPUT RPM	169	82	56	43	33	28	17
	OUTPUT TORQUE IN. LBS.	21618	25388	27022	28107	28027	28599	28994
690	INPUT HORSEPOWER	49.4	28.5	20.5	15.9	12.3	10.7	6.6
	OUTPUT RPM	137	67	45	35	27	23	14
	OUTPUT TORQUE IN. LBS.	22307	26438	27867	28433	28506	28739	29167
100	INPUT HORSEPOWER	9.26	4.59	3.13	2.38	1.84	1.59	.96
	OUTPUT RPM	19.8	9.7	6.6	5.0	3.9	3.3	2.0
	OUTPUT TORQUE IN. LBS.	28824	29400	29400	29400	29400	29400	29400

BORE TOLERANCE NOMINAL +.003

F-40

CALL: (605) 225-0360



FAX: (605) 225-0567

VISIT OUR WEB SITE AT WWW.CLARKTR.COM

Model 5 - Double Reduction

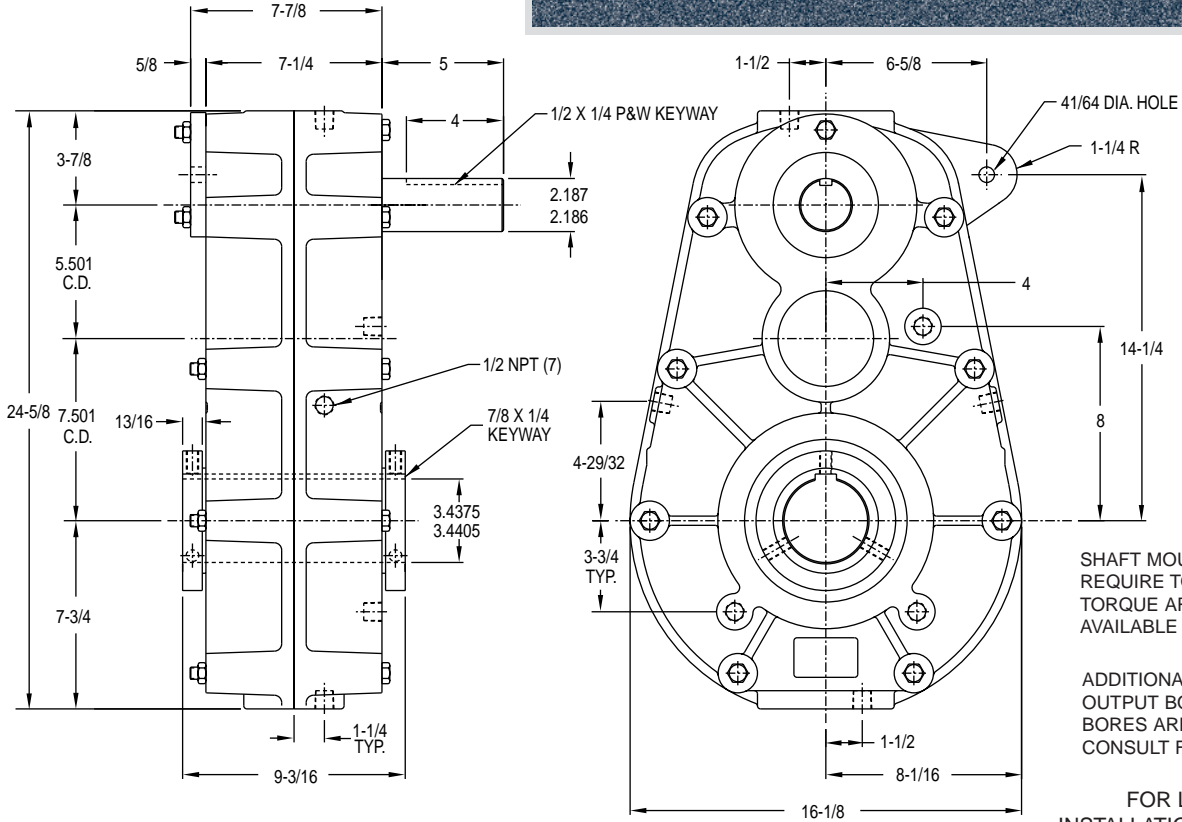

SHAFT MOUNTED UNITS REQUIRE TORQUE ARMS. TORQUE ARM KITS ARE AVAILABLE SEE PAGE F-51.

ADDITIONAL RATIOS, OUTPUT BORES AND INPUT BORES ARE AVAILABLE — CONSULT FACTORY.

FOR LUBRICATION AND INSTALLATION INSTRUCTIONS - REFER TO SECTION R

DIMENSIONS SHOWN ARE FOR REFERENCE ONLY. CERTIFIED PRINTS ARE AVAILABLE UPON REQUEST.

SEE CHART FOR (QTY) J HOLES ON K B.C. FOR EACH FLANGE SIZE

DRY SHIPPING WEIGHT 360 LBS.

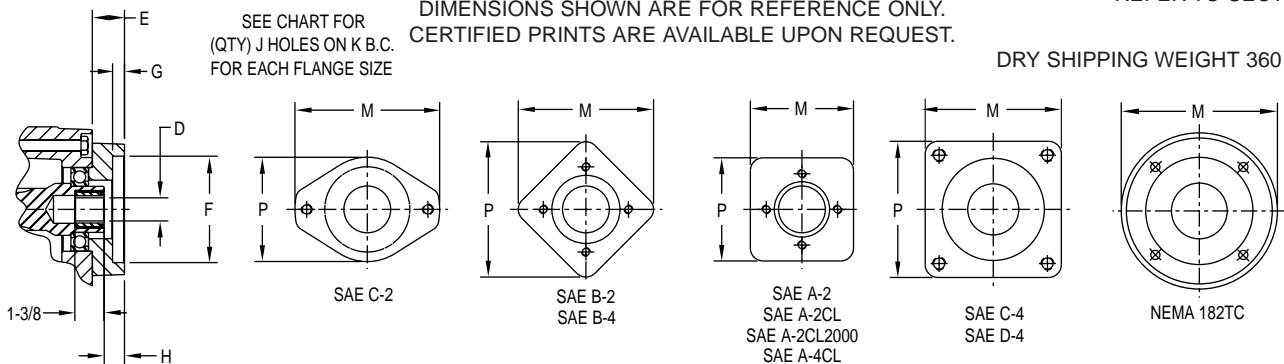

INPUT BUSHING SIZES			
D			
1.000 DIA. - 1/4 X 1/8 KW	1.250 DIA. - 5/16 X 1/8 KW	13T - 16/32 D.P. SPLINE	21T - 16/32 D.P. SPLINE
1.125 DIA. - 1/4 X 1/8 KW	1" - 6B SPLINE	14T - 12/24 D.P. SPLINE	
1.250 DIA. - 1/4 X 1/8 KW	9T - 16/32 D.P. SPLINE	15T - 16/32 D.P. SPLINE	

FLANGE	E	COUNTERBORE F	G	H	(QTY) J HOLES	B.C. DIA. K	M	P
A-2	1-3/8	3.251 / 3.253	5/16	53/64	(2) 3/8 NC	4-3/16	6-1/16	6-1/16
A-2CL	1-3/8	3.251 / 3.253	3/16	53/64	(2) 1/2 NC	4-3/16	6-1/16	6-1/16
A-2CL2000	1-3/8	3.251 / 3.253	5/16	53/64	(2) 1/2 NC	4-3/16	6-1/16	6-1/16
A-4CL	1-3/8	3.251 / 3.253	3/16	53/64	(4) 1/2 NC	4-3/16	6-1/16	6-1/16
B-2	1-3/8	4.001 / 4.003	7/16	53/64	(2) 1/2 NC	5-3/4	6-1/16	6-1/16
B-4	1-3/8	4.001 / 4.003	7/16	53/64	(4) 1/2 NC	5	6-1/16	6-1/16
C-2	1-1/2	5.001 / 5.003	9/16	31/32	(2) 5/8 NC	7-1/8	8-1/2	6-1/8
C-4	1-1/2	5.001 / 5.003	9/16	31/32	(4) 1/2 NC	6-3/8	6-1/16	6-1/16
D-4	1-1/2	6.001 / 6.003	9/16	31/32	(4) 3/4 NC	9	8	8
182TC	2-7/16	8.501 / 8.504	5/16	1-57/64	(4) 17/32 DIA.	7-1/4	9-1/8	—

F

Double Reduction

HUB CITY PARALLEL SHAFT DRIVES

Model 6 - Double Reduction

Features

- ◆ Rugged cast iron housing designed for rigid gear and bearing support.
- ◆ Alloy shafting and sleeves for greater strength.
- ◆ Tapered roller bearings on all shafts.
- ◆ Choice of seven (7) standard gear ratios.
- ◆ Heat treated alloy steel gearing for strength and long wear life.
- ◆ Heavy-duty industrial seals to keep lubricant in and dirt out.
- ◆ Shaft mount design for direct mounting on the drive shaft of equipment to be driven.
- ◆ HUB CITY lubricant recommended. (Refer to Section R)



DOUBLE REDUCTION UNITS PROVIDE SAME DIRECTION OUTPUT ROTATION

Rating Table

Input RPM		RATIOS						
		5.16:1	10.48:1	15.23:1	19.99:1	24.84:1	29.32:1	50.69:1
1750	INPUT HORSEPOWER	136.9	76.5	55.8	46.2	37.1	33.7	20.7
	OUTPUT RPM	339	167	115	88	70	60	35
	OUTPUT TORQUE IN. LBS.	24935	28297	30000	32597	32487	34909	37101
1150	INPUT HORSEPOWER	97.9	54.1	41.3	32.8	26.3	23.5	13.8
	OUTPUT RPM	223	110	76	58	46	39	23
	OUTPUT TORQUE IN. LBS.	27119	30476	33745	35197	35700	36958	37536
850	INPUT HORSEPOWER	75.7	43.7	31.9	25.3	20.3	17.5	10.3
	OUTPUT RPM	165	81	56	43	34	29	17
	OUTPUT TORQUE IN. LBS.	28381	33275	35294	36711	36606	37317	37870
690	INPUT HORSEPOWER	63.3	36.8	26.7	20.8	16.7	14.3	8.4
	OUTPUT RPM	134	66	45	35	28	24	14
	OUTPUT TORQUE IN. LBS.	29246	34532	36398	37137	37101	37500	38095
100	INPUT HORSEPOWER	11.8	5.93	4.08	3.11	2.50	2.12	1.23
	OUTPUT RPM	19.4	9.5	6.6	5.0	4.0	3.4	2.0
	OUTPUT TORQUE IN. LBS.	37721	38400	38400	38400	38400	38400	38400

Model 6 - Double Reduction

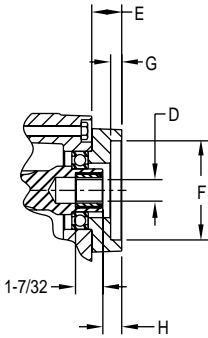
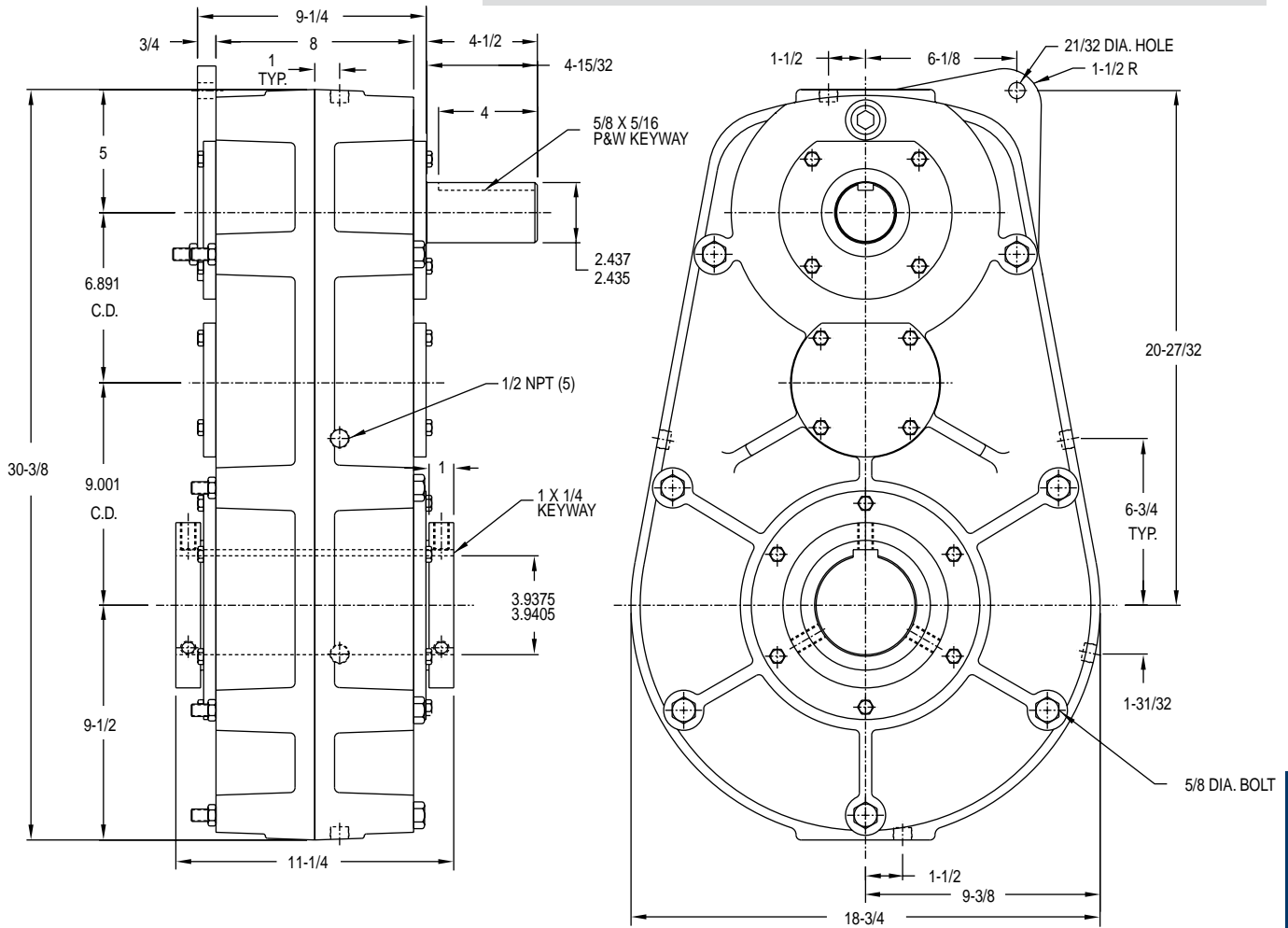

SEE CHART FOR (QTY) J HOLES ON K B.C. FOR EACH FLANGE SIZE

DIMENSIONS SHOWN ARE FOR REFERENCE ONLY. CERTIFIED PRINTS ARE AVAILABLE UPON REQUEST.

SHAFT MOUNTED UNITS REQUIRE TORQUE ARMS. TORQUE ARM KITS ARE AVAILABLE SEE PAGE F-51.

ADDITIONAL RATIOS, OUTPUT BORES AND INPUT BORES ARE AVAILABLE — CONSULT FACTORY.

FOR LUBRICATION AND INSTALLATION INSTRUCTIONS - REFER TO SECTION R

DRY SHIPPING WEIGHT 480 LBS.

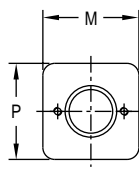

SAE A-2
SAE A-2CL

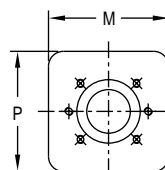

SAE B-2
SAE B-4
SAE C-2
SAE C-4

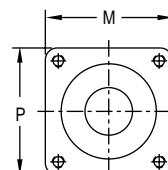

SAE D-2
SAE D-4

INPUT BUSHING SIZES

D		
1.000 DIA. - 1/4 X 1/8 KW	13T - 16/32 D.P. SPLINE	15T - 16/32 D.P. SPLINE
9T - 16/32 D.P. SPLINE	14T - 12/24 D.P. SPLINE	21T - 16/32 D.P. SPLINE

FLANGE	E	COUNTERBORE F	G	H	(QTY) J HOLES	B.C. DIA. K	M	P
A-2	7/8	3.251 / 3.253	--	5/8	(2) 3/8 NC	4-3/16	8-3/8	8-3/8
A-2CL	7/8	3.251 / 3.253	--	5/8	(2) 1/2 NC	4-3/16	8-3/8	8-3/8
B-2	7/8	4.001 / 4.003	--	5/8	(2) 1/2 NC	5-3/4	8-3/8	8-3/8
B-4	7/8	4.001 / 4.003	--	5/8	(4) 1/2 NC	5	8-3/8	8-3/8
C-2	7/8	5.001 / 5.003	9/16	5/8	(2) 5/8 NC	7-1/8	8-3/8	8-3/8
C-4	7/8	5.001 / 5.003	9/16	5/8	(4) 1/2 NC	6-3/8	8-3/8	8-3/8
D2-4	7/8	6.001 / 6.003	9/16	5/8	(4) 25/32 DIA.	9	8-3/8	8-3/8

Double Reduction

HUB CITY PARALLEL SHAFT DRIVES

Model 75 - Double Reduction

Features

- ◆ Rugged Ductile iron housing designed for rigid gear and bearing support.
- ◆ Alloy shafting and sleeves for greater strength.
- ◆ Precision bearings on all shafts.
- ◆ Choice of nine (9) standard gear ratios.
- ◆ Heat treated alloy steel gearing for strength and long wear life.
- ◆ Heavy-duty industrial seals to keep lubricant in and dirt out.
- ◆ Shaft mount design for direct mounting on the drive shaft of equipment to be driven.
- ◆ HUB CITY lubricant recommended. (Refer to Section R)

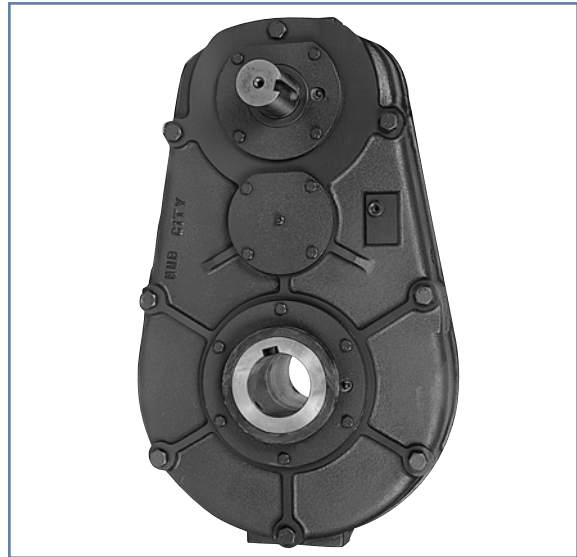

DOUBLE REDUCTION UNITS PROVIDE SAME DIRECTION OUTPUT ROTATION

Rating Table

Input RPM		RATIOS								
		5.06:1	9.9:1	15.37:1	20:1	25.56:1	29.38:1	39.85:1	49.3:1	59.76:1
1750	INPUT HORSEPOWER	252.8	146.8	121.5	95.7	89.0	79.0	54.4	39.7	32.1
	OUTPUT RPM	346	177	114	88	68	60	44	35	29
	OUTPUT TORQUE IN. LBS.	46019	52329	67301	68940	80624	81506	79727	70441	69056
1150	INPUT HORSEPOWER	175.0	100.9	82.1	67.9	59.3	52.0	37.9	26.9	21.7
	OUTPUT RPM	227	116	75	58	45	39	29	23	19
	OUTPUT TORQUE IN. LBS.	48475	54744	69217	74461	82395	81395	81125	72866	71281
850	INPUT HORSEPOWER	133.7	76.8	61.7	51.5	44.9	39.0	27.2	20.3	16.4
	OUTPUT RPM	168	86	55	43	33	29	21	17	14
	OUTPUT TORQUE IN. LBS.	50122	56339	70444	76432	82389	83279	82228	74429	72705
690	INPUT HORSEPOWER	110.9	63.4	50.6	42.5	36.4	32.0	22.3	16.7	13.5
	OUTPUT RPM	136	70	45	35	27	23	17	14	12
	OUTPUT TORQUE IN. LBS.	51195	57368	71213	77696	83279	84167	82820	75419	73615
100	INPUT HORSEPOWER	18.4	10.3	7.9	6.8	5.5	4.8	3.4	2.6	2.1
	OUTPUT RPM	19.8	10.1	6.5	5.0	3.9	3.4	2.5	2.0	1.7
	OUTPUT TORQUE IN. LBS.	58585	64233	75960	85983	86822	86822	86402	81728	79313

Model 75 - Double Reduction

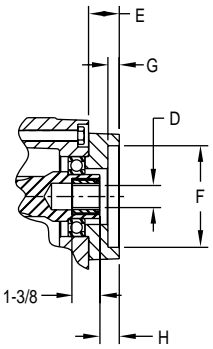
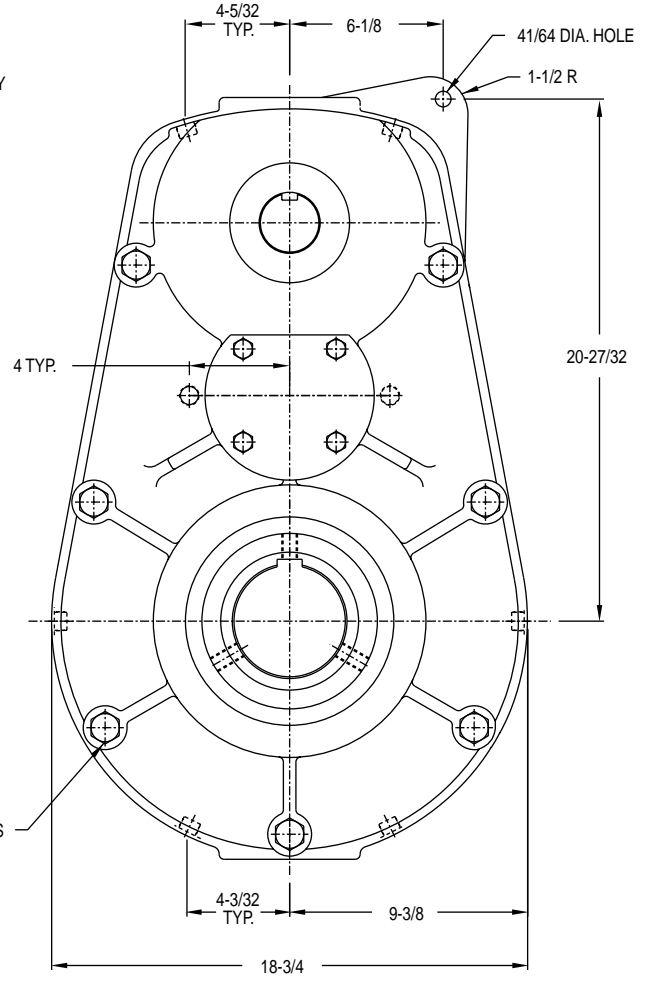
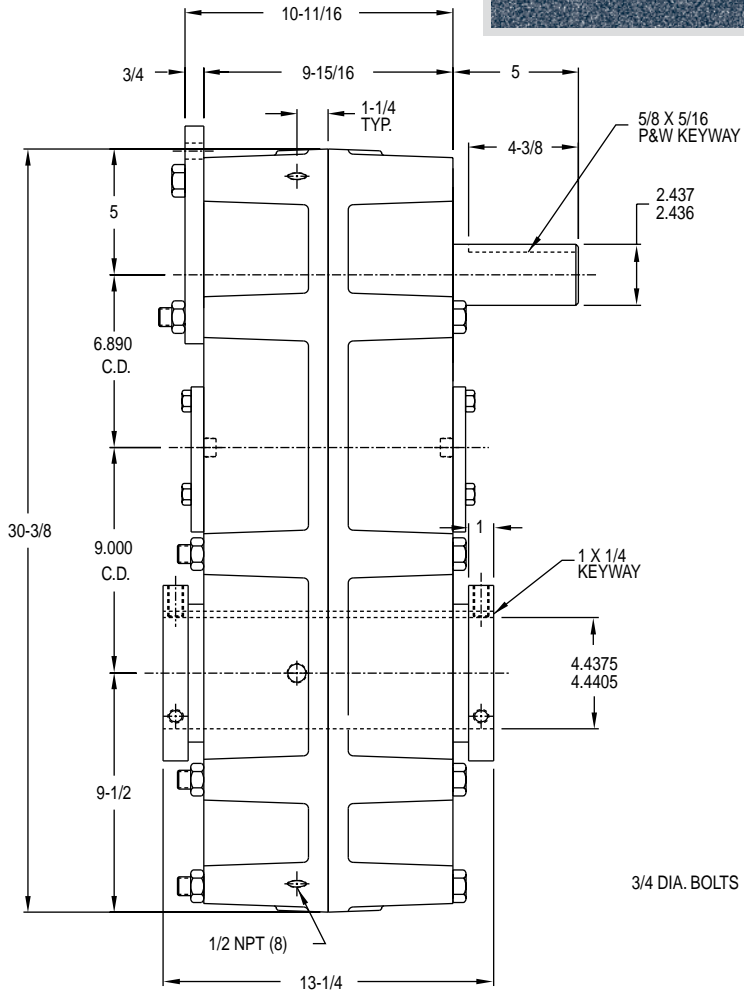

SEE CHART FOR (QTY) J HOLES ON K.B.C. FOR EACH FLANGE SIZE

DIMENSIONS SHOWN ARE FOR REFERENCE ONLY. CERTIFIED PRINTS ARE AVAILABLE UPON REQUEST.

SHAFT MOUNTED UNITS REQUIRE TORQUE ARMS. TORQUE ARM KITS ARE AVAILABLE SEE PAGE F-51.

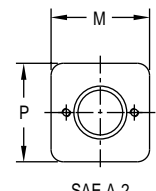
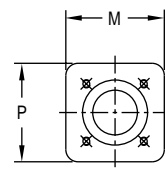
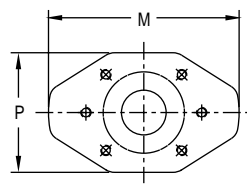

ADDITIONAL RATIOS, OUTPUT BORES AND INPUT BORES ARE AVAILABLE — CONSULT FACTORY.

FOR LUBRICATION AND INSTALLATION INSTRUCTIONS - REFER TO SECTION R

DRY SHIPPING WEIGHT 550 LBS.

INPUT BUSHING SIZES			
D			
1.000 DIA. - 1/4 X 1/8 KW	1.250 DIA. - 5/16 X 1/8 KW	13T - 16/32 D.P. SPLINE	21T - 16/32 D.P. SPLINE
1.125 DIA. - 1/4 X 1/8 KW	1" - 6B SPLINE	14T - 12/24 D.P. SPLINE	
1.250 DIA. - 1/4 X 1/8 KW	9T - 16/32 D.P. SPLINE	15T - 16/32 D.P. SPLINE	

FLANGE	E	COUNTERBORE F	G	H	(QTY) J HOLES	B.C. DIA. K	M	P
A-2	1	3.251 / 3.253	--	5/8	(2) 3/8 NC	4-3/16	8	8
A-2CL	1	3.251 / 3.253	--	5/8	(2) 1/2 NC	4-3/16	8	8
B-2	1	4.001 / 4.003	--	5/8	(2) 1/2 NC	5-3/4	8	8
B-4	1	4.001 / 4.003	--	5/8	(4) 1/2 NC	5	8	8
C-2	1	5.001 / 5.003	9/16	5/8	(2) 5/8 NC	7-1/8	10-5/8	8-1/2
C-4	1	5.001 / 5.003	9/16	5/8	(4) 1/2 NC	6-3/8	10-5/8	8-1/2

F

Double Reduction

HUB CITY PARALLEL SHAFT DRIVES

Model 8 - Double Reduction

Features

- ◆ Rugged Ductile iron housing designed for rigid gear and bearing support.
- ◆ Alloy shafting and sleeves for greater strength.
- ◆ Precision bearings on all shafts.
- ◆ Choice of five (5) standard gear ratios.
- ◆ Heat treated alloy steel gearing for strength and long wear life.
- ◆ Heavy-duty industrial seals to keep lubricant in and dirt out.
- ◆ Shaft mount design for direct mounting on the drive shaft of equipment to be driven.
- ◆ HUB CITY lubricant recommended. (Refer to Section R)



DOUBLE REDUCTION UNITS PROVIDE SAME DIRECTION OUTPUT ROTATION

Rating Table

Input RPM		RATIOS				
		5.16:1	10.46:1	15.21:1	24.90:1	29.82:1
1750	INPUT HORSEPOWER	291.0	181.1	181.1	119.0	101.7
	OUTPUT RPM	339	167	115	70	59
	OUTPUT TORQUE IN. LBS.	53002	66871	97235	104607	107060
1150	INPUT HORSEPOWER	205.1	126.5	126.4	80.8	69.0
	OUTPUT RPM	223	110	76	46	39
	OUTPUT TORQUE IN. LBS.	56848	71094	103376	108114	110434
850	INPUT HORSEPOWER	158.7	97.3	96.4	61.0	52.0
	OUTPUT RPM	165	81	56	34	29
	OUTPUT TORQUE IN. LBS.	59496	73950	106583	110359	112585
690	INPUT HORSEPOWER	132.6	81.0	79.5	50.1	42.7
	OUTPUT RPM	134	66	45	28	23
	OUTPUT TORQUE IN. LBS.	61252	75822	108257	111775	113939
100	INPUT HORSEPOWER	23.24	13.77	12.67	7.84	6.64
	OUTPUT RPM	19.4	9.6	6.6	4.0	3.3
	OUTPUT TORQUE IN. LBS.	74057	88932	119006	120646	122361

Model 8 - Double Reduction

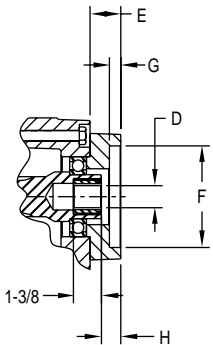
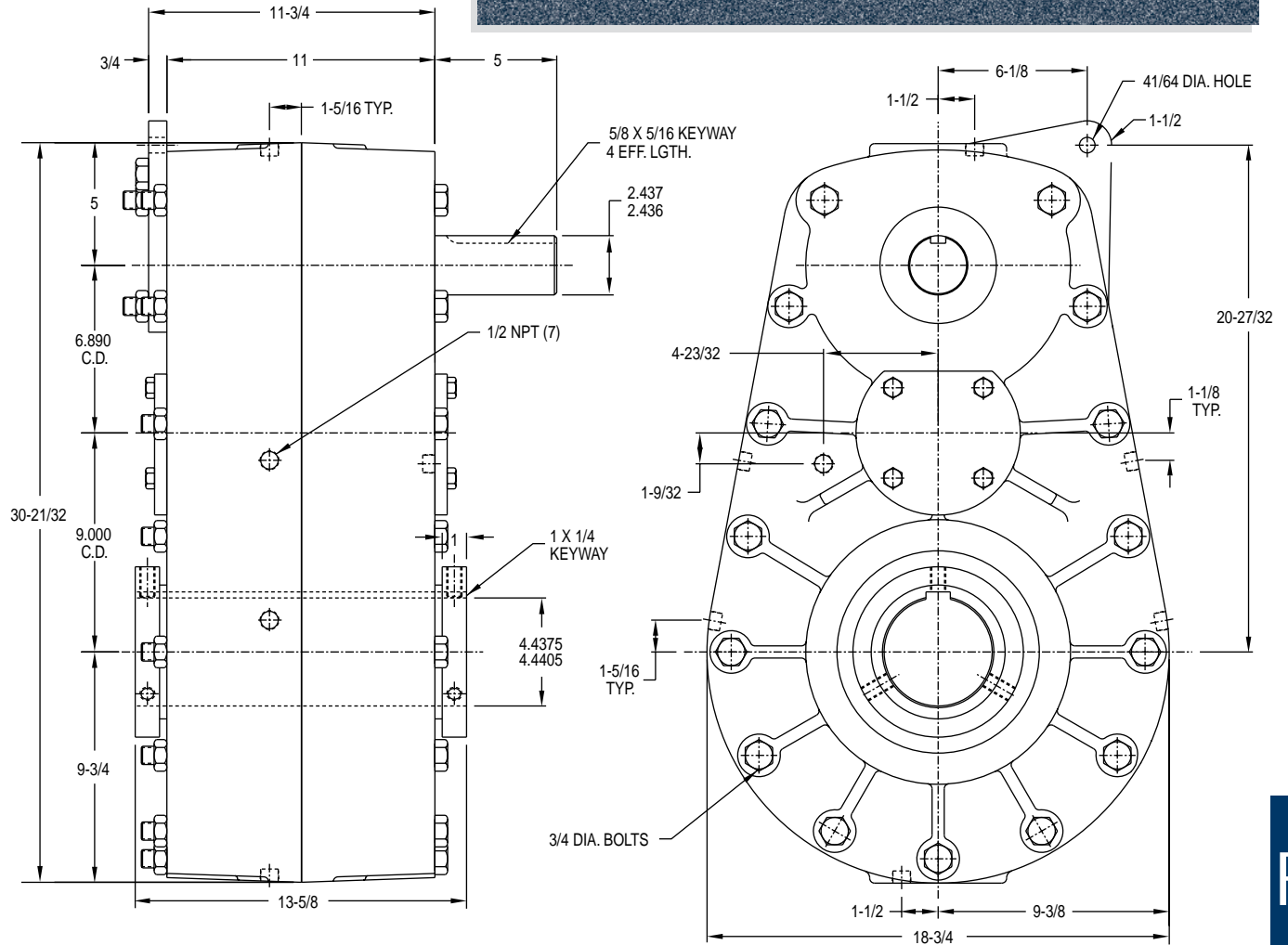

SEE CHART FOR (QTY) J HOLES ON K B.C. FOR EACH FLANGE SIZE

DIMENSIONS SHOWN ARE FOR REFERENCE ONLY. CERTIFIED PRINTS ARE AVAILABLE UPON REQUEST.

SHAFT MOUNTED UNITS REQUIRE TORQUE ARMS. TORQUE ARM KITS ARE AVAILABLE SEE PAGE F-51.

ADDITIONAL RATIOS, OUTPUT BORES AND INPUT BORES ARE AVAILABLE — CONSULT FACTORY.

FOR LUBRICATION AND INSTALLATION INSTRUCTIONS - REFER TO SECTION R

DRY SHIPPING WEIGHT 725 LBS.

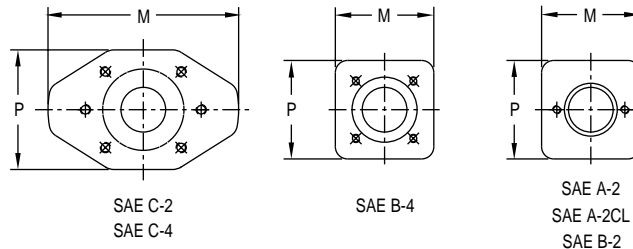

INPUT BUSHING SIZES

D			
1.000 DIA. - 1/4 X 1/8 KW	1.250 DIA. - 5/16 X 1/8 KW	13T - 16/32 D.P. SPLINE	21T - 16/32 D.P. SPLINE
1.125 DIA. - 1/4 X 1/8 KW	1" - 6B SPLINE	14T - 12/24 D.P. SPLINE	
1.250 DIA. - 1/4 X 1/8 KW	9T - 16/32 D.P. SPLINE	15T - 16/32 D.P. SPLINE	

FLANGE	E	COUNTERBORE F	G	H	(QTY) J HOLES	B.C. DIA. K	M	P
A-2	1	3.251 / 3.253	--	15/16	(2) 3/8 NC	4-3/16	8	8
A-2CL	1	3.251 / 3.253	--	15/16	(2) 1/2 NC	4-3/16	8	8
B-2	1	4.001 / 4.003	--	15/16	(2) 1/2 NC	5-3/4	8	8
B-4	1	4.001 / 4.003	--	15/16	(4) 1/2 NC	5	8	8
C-2	1	5.001 / 5.003	9/16	15/16	(2) 5/8 NC	7-1/8	10-5/8	8-1/2
C-4	1	5.001 / 5.003	9/16	15/16	(4) 1/2 NC	6-3/8	10-5/8	8-1/2

Double Reduction

HUB CITY PARALLEL SHAFT DRIVES

Model HT-100 Shifting Transmission

Features

- ◆ Input and output shafts in-line.
- ◆ Shifting mechanism allows selection of neutral and two (2) ratios.
- ◆ Rugged cast iron housing designed for rigid gear and bearing support.
- ◆ Alloy shafting for greater strength.
- ◆ Heavy-duty ball bearings on input and output shafts.
- ◆ Needle bearings on pilot and counter shaft.
- ◆ Heat treated alloy steel gearing for strength and long wear life.
- ◆ Choice of 1:1 and two (2) standard gear ratios.
- ◆ Heavy-duty industrial seals to keep lubricant in and dirt out.
- ◆ Available with hydraulic flange or shaft input.
- ◆ HUB CITY lubricant recommended. (Refer to Section R)
- ◆ HT-100 manufactured to order only. Consult factory for price and delivery.

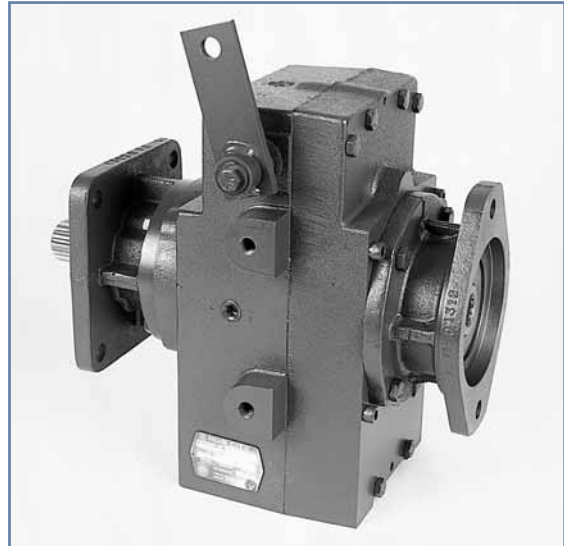

Rating Table

INPUT		RATIOS					
		1:1	AND	2.20:1	1:1	AND	2.86:1
1750	INPUT HORSEPOWER	32.8		22.7		32.8	15.9
	OUTPUT RPM	1750		797		1750	612
	OUTPUT TORQUE IN. LBS.	1181		1794		1181	1637
1150	INPUT HORSEPOWER	23.1		15.9		23.1	11.0
	OUTPUT RPM	1150		524		1150	402
	OUTPUT TORQUE IN. LBS.	1266		1915		1266	1725
850	INPUT HORSEPOWER	17.9		12.3		17.9	8.4
	OUTPUT RPM	850		387		850	297
	OUTPUT TORQUE IN. LBS.	1327		1997		1327	1772
690	INPUT HORSEPOWER	14.9		10.2		14.9	6.9
	OUTPUT RPM	690		314		690	241
	OUTPUT TORQUE IN. LBS.	1361		2049		1361	1804
100	INPUT HORSEPOWER	2.6		1.7		2.6	1.1
	OUTPUT RPM	100		46		100	35
	OUTPUT TORQUE IN. LBS.	1639		2370		1639	1981

Overhung Load - Input 450 LBS.
Output 550 LBS.

Model HT-100 Shifting Transmission

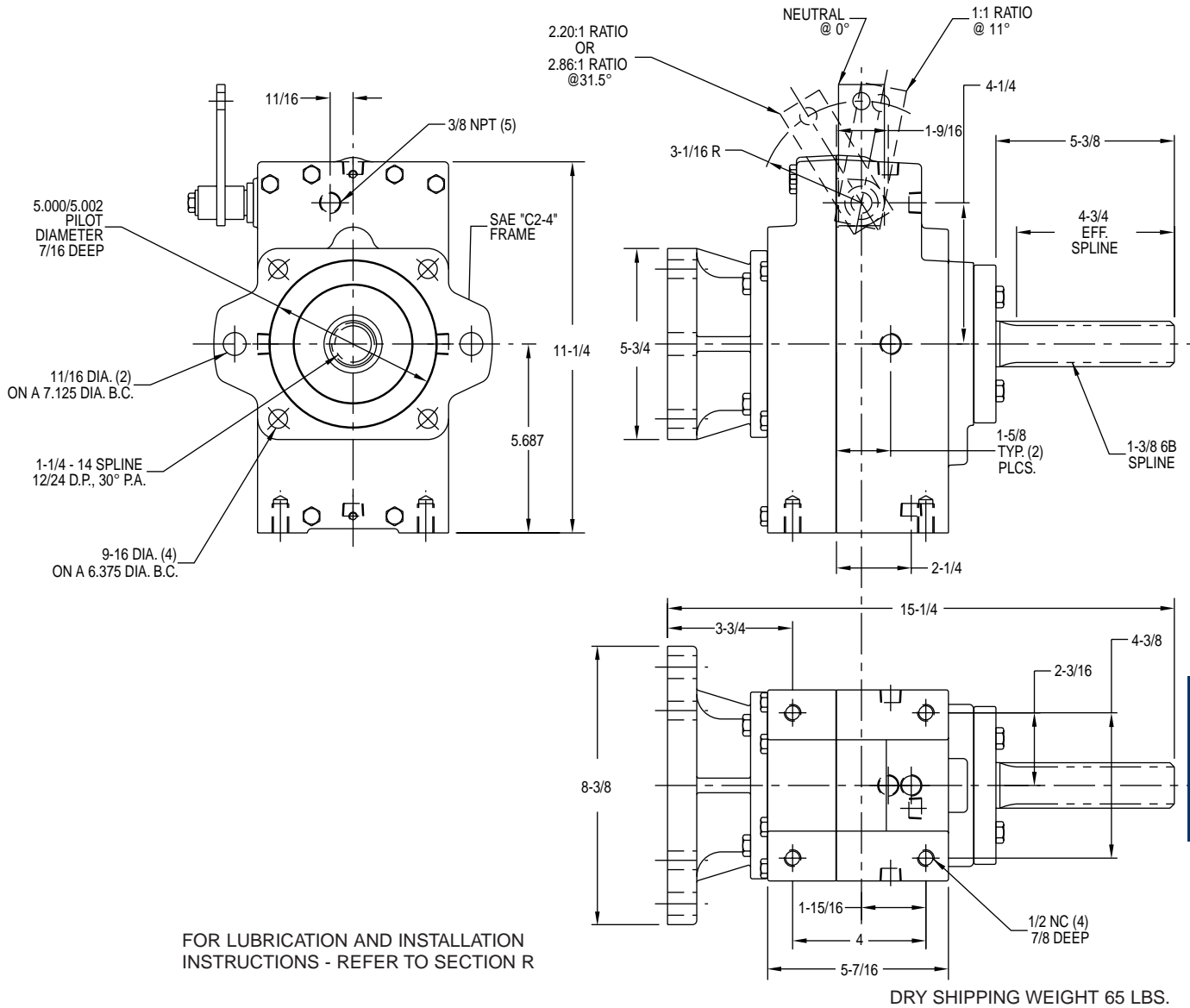

Alternate Input Design

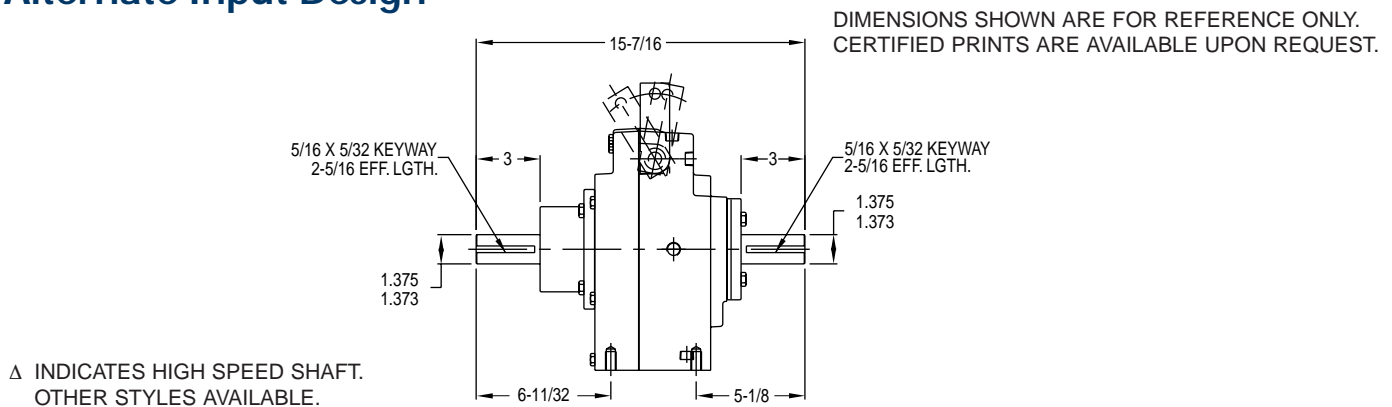

CONSULT FACTORY FOR VERTICAL SHAFT LUBRICATION RECOMMENDATIONS
INPUT SHAFT CAN BE ROTATED IN EITHER DIRECTION

HUB CITY PARALLEL SHAFT DRIVES

SAE Standards

SAE J744 Hydraulic Power, Pumps

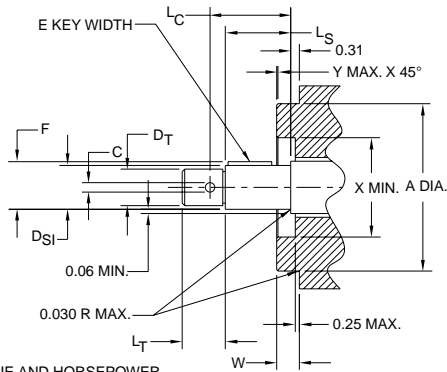

TOLERANCES
 2 PLACE DIMENSIONS ±0.030
 3 PLACE DIMENSIONS ±0.010
 SLOTS INSTEAD OF HOLES OPTIONAL
 DIMENSIONAL SYSTEM REFERENCE:
 ANS I Y 14.5 (1966)

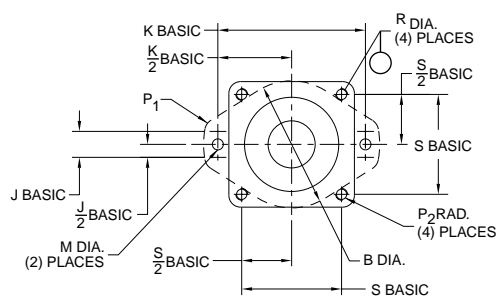

TORQUE AND HORSEPOWER REQUIREMENTS NOTED ARE TYPICAL VALUES AND SHOULD BE CONSIDERED AS A GUIDE ONLY.

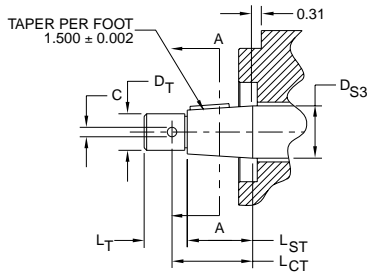

SAE J498b, CLASS 1, FLAT ROOT SIDE FIT. FOR SPLINE DIMENSIONS REFER TO SPLINE TABLES

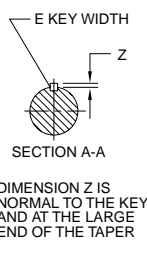

DIMENSION Z IS NORMAL TO THE KEY AND AT THE LARGE END OF THE TAPER

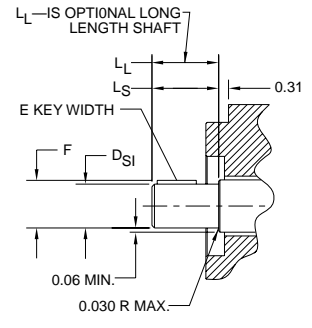

TABLE 1 — DIMENSIONS OF HYDRAULIC POWER PUMP AND MOTOR MOUNTING FLANGE AND SHAFTS RELATED TO HORSEPOWER REQUIREMENTS

Mounting Flange and Shaft Size	Shaft ^a S1 = 25,000 psi		Shaft Dimensions															
			Straight with Thread								Tapered							
			D _{S1}	D _T	C +0.005 -0.003	L _C	L _S	L _T	E +0.001 -0.000	F ±0.005	D _{S3}	D _T	C +0.005 -0.003	L _{CT}	L _{ST}	L _T	E +0.001 -0.000	Z
A-A	260	4.25	0.500 0.499	3/8-24 UNF 2A	0.094	1.125	0.750	0.562	0.125	0.664	0.500 0.499	5/16-32 UNF 2A	0.078	0.984	0.688	0.500	0.125	0.064 0.054
A	517	8.25	0.625 0.624	1/2-20 UNF 2A	0.125	1.344	0.938	0.719	0.1563	0.693	0.625 0.624	1/2-20 UNF 2A	0.125	1.094	0.688	0.719	0.1563	0.084 0.074
B	1,852	29.3	0.875 0.874	5/8-18 UNF 2A	0.156	1.875	1.312	0.906	0.250	0.982	0.875 0.874	5/8-18 UNF 2A	0.156	1.688	1.125	0.906	0.250	0.131 0.121
B-B	2,987	47.5	1.000 0.998	3/4-16 UNF 2A	0.156	2.062	1.500	1.062	0.250	1.106	1.001 0.999	3/4-16 UNF 2A	0.156	1.938	1.375	1.062	0.250	0.131 0.121
C	5,677	90.0	1.250 1.248	1-12 UNF 2A	0.156	2.625	1.875	1.219	0.3125	1.386	1.251 1.249	1-12 UNF 2A	0.156	1.938	1.375	1.219	0.3125	0.162 0.152
C-C	10,777	171	1.500 1.498	1-1/8-12 UNF 2A	0.156	2.875	2.125	1.375	0.375	1.664	1.501 1.499	1-1/8-12 UNF 2A	0.156	2.438	1.875	1.375	0.375	0.194 0.184
D	15,057	239	1.750 1.748	1-1/4-12 UNF 2A	0.156	3.500	2.625	1.562	0.4375	1.941	1.751 1.749	1-1/4-12 UNF 2A	0.156	2.812	2.125	1.562	0.4375	0.225 0.215
E	15,057	238	1.750 1.748	1-1/4-12 UNF 2A	0.156	3.500	2.625	1.562	0.4375	1.941	1.751 1.749	1-1/4-12 UNF 2A	0.156	2.812	2.125	1.562	0.4375	0.225 0.215
F	24,245	285	-	-	-	-	-	-	-	-	2.001 1.999	1-1/4-12 UNF 2A	0.156	3.562	2.875	1.562	0.500	0.256 0.246

SAE Standards

SAE J744 Hydraulic Power, Pumps

Mounting Flange and Shaft Size	Shaft ^a S1= 25,000 psi Torque in.-lb. hp at 1000 rpm		Shaft Dimensions										Pilot Dimensions Common to 2 and 4 Bolt Flanges			
			30 deg. Involute Spline					Straight without Thread					A +0.000 -0.002	W +0.000 -0.020	X min	Y max
			U Spline	min	L _A	L _S	L _B	D _{S1}	L _S	E +0.001 -0.000	L _L	F ±0.005				
A-A	260	4.25	9T 20/40 DP	0.3760	0.20	0.750	0.06	$\frac{0.500}{0.499}$	0.750	0.125	-	0.554	2.000	0.250	-	0.00
A	517	8.25	9T 16/32 DP	0.4725	0.30	0.938	0.06	$\frac{0.625}{0.624}$	0.938	0.1563	2.00	0.693	3.250	0.250	-	0.00
B	1,852	29.3	13T 16/32 DP	0.7225	0.40	1.312	0.06	$\frac{0.875}{0.874}$	1.312	0.250	2.50	0.982	4.000	0.380	2.00	0.04
B-B	2,987	47.5	15T 16/32 DP	0.8475	0.50	1.500	0.06	$\frac{1.000}{0.998}$	1.500	0.250	2.75	1.106	4.000	0.380	2.00	0.04
C	5,677	90.0	14T 12/24 DP	1.0497	0.60	1.875	0.09	$\frac{1.250}{1.248}$	1.875	0.3125	3.00	1.386	5.000	0.500	2.50	0.04
C-C	10,777	171	17T 12/24 DP	1.2997	0.70	2.125	0.09	$\frac{1.500}{1.498}$	2.125	0.375	3.25	1.664	5.000	0.500	2.50	0.04
D	15,057	239	13T 8/16 DP	1.4530	0.80	2.625	0.12	$\frac{1.750}{1.748}$	2.626	0.4375	3.62	1.941	6.000	0.500	2.75	0.04
E	15,067	239	13T 8/16 DP	1.4530	0.80	2.625	0.12	$\frac{1.750}{1.748}$	2.625	0.4375	3.62	1.941	6.5000	0.625	2.75	0.09
F	24,245	285	15T 8/16 DP	1.7030	1.00	3.125	0.12	-	-	-	-	-	7.000	0.625	2.75	0.09

Mounting Flange and Shaft Size	Shaft ^a S1= 25,000 psi Torque in.-lb. hp at 1000 rpm		Flange Dimensions							
			2 Bolt Type				4 Bolt Type			
			K	M +0.010 -0.005	P ₁ Radius	B	J	S	R +0.010 -0.005	P ₂
A-A	260	4.25	3.250	0.406	0.38	2.50	0.56	-	-	-
A	517	8.25	4.188	0.438	0.47	3.75	0.72	-	-	-
B	1,852	29.3	5.750	0.562	0.56	4.75	0.99	3.536	0.562	0.56
B-B	2,987	47.5	5.750	0.562	0.56	4.75	0.99	3.536	0.562	0.56
C	5,677	90.0	7.125	0.688	0.62	5.81	1.22	4.508	0.562	0.62
C-C	10,777	171	7.125	0.688	0.62	5.81	1.22	4.508	0.562	0.62
D	15,057	239	9.000	0.812	0.75	7.88	1.55	6.364	0.812	0.75
E	15,057	239	12.500	1.062	1.00	10.62	2.15	8.839	0.812	0.75
F	24,245	285	13.781	1.062	1.00	11.75	2.37	9.745	1.062	1.00

a Torsional stress calculated at spline shaft undercut (U dimension, min) with no stress riser considered. Torque and horsepower requirements noted are typical values and should be considered as a guide only.

Accessories

TORQUE ARMS

Torque Arm	AA	BB Max.	BB Min.	CC Bolts	DD	EE	FF Bolts	GG	HH
A	5/8	19-5/16	13-5/16	7/16 Dia.	1-1/2	1-5/16	3/8	3	4
B	15/16	35-1/8	23-1/8	5/8 Dia.	2-3/8	1-3/4	5/8	4-1/2	6

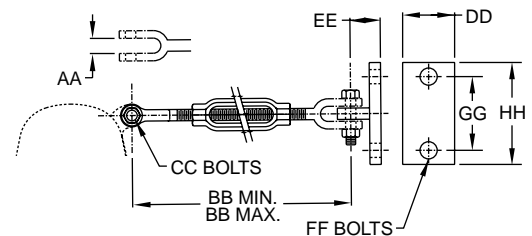

TORQUE ARMS APPLICATION CHART

Torque Arm	Mod. 1	Mod. 2	Mod. 3	Mod. 4	Mod. 5	Mod. 6	Mod. 75	Mod. 8	Mod. 52	Mod. 83L	Mod. 89	Mod. 85L	Mod. 95L
A	X	X	X	X					X	X	X	X	X
B						X	X	X	X				

HUB CITY PARALLEL SHAFT DRIVES

Factory Options

The following factory options are available for gear drives in this catalog. Contact the factory for details on price, availability, and specifications.

CleanLine™

When application conditions demand premium washdown duty gear drives.

Features

FDA approved white acrylic paint
Corrosion resistant shaft treatment or stainless steel shafts
Stainless steel hardware and nameplate

Options

Motorized versions
BISSC Standards

Metric Versions

Features

Metric Motor flanges
Metric shaft dimensions
Metric mounting dimensions

Options

Motorized versions
Modified and Custom Designs

Backstops

Backstops are available for applications that require the prevention of reverse rotation. Backstops must be factory assembled.

Modified and Custom Designs

If you have looked through this catalog and do not see exactly what you need, Hub City has the capability and engineering expertise to design and produce a special drive. Capabilities range from flange and shaft modifications, to custom housing dimensions. Consult the factory or your Hub City representative with your specifications.